

# ENGINEERING DATA SHEET

# SPDU SERIES

28 VDC NEXT GENERATION  
SECONDARY POWER DISTRIBUTION UNIT WITH  
22 SSPCs UP TO 5A, DC RATING  
AND 6 SSPCs UP TO 10A, DC RATING



SIZE: 6.1" x 12.1" x 5.7"

## DESCRIPTION

The SPDU is an equipment that distributes the 28 Vdc power to the aircraft loads and provides protection for their wiring. The SPDU can receive its input power from multiple sources and controls the loads based on the commands received through the data bus. The SSPCs can be commanded ON, OFF or reset through the data bus. The status of each load and the switch can be interrogated through the data bus. The SSPCs provide combined switching for the load and protection for the wiring. Lightweight, approximately 6.75 lbs.

**NOTE: Assemblies can be configured and qualified to customer-specific requirements. Contact your Leach International sales representative for further information.**

## FEATURES

- 28-channel Solid State Power Controllers (SSPCs)
- Standard dual redundant power supplies
- Standard dual redundant data bus
- Control option via a data bus, discrete signal or manual push buttons
- 6 channels rated at 10 Amps to 85°C
- 22 channels rated at 5 Amps to 85°C
- High current channel(s) in rear face (optional)
- Extensive BIT (Start-up, Continuous and initiated)
- Channels are programmable to 25%, 50%, or 75% of their rated value.
- Optional different types of data bus (MIL-STD-1553B, ARINC 429, ARINC 485, RS-232, and CAN Bus)
- Higher ratings and number of output channels available.
- Flexible architecture to accommodate different power inputs and number of SSPCs and ratings of SSPCs.

## UNIT ARCHITECTURE

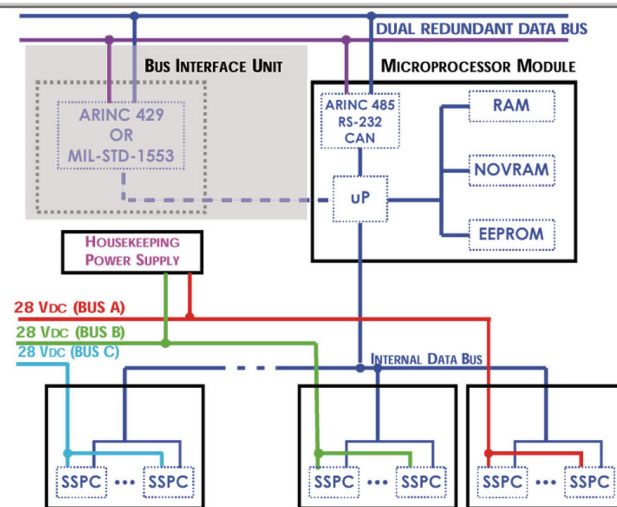

Featuring **LEACH**® power and control solutions  
www.esterline.com

**AMERICAS**  
6900 Orangethorpe Ave.  
P.O. Box 5032  
Buena Park, CA 90622

Tel: (01) 714-736-7599  
Fax: (01) 714-670-1145

**EUROPE**  
2 Rue Goethe  
57430 Sarralbe  
France

Tel: (33) 3 87 97 31 01  
Fax: (33) 3 87 97 96 86

**ASIA**  
Units 602-603 6/F Lakeside 1  
No.8 Science Park West Avenue  
Phase Two, Hong Kong Science Park  
Pak Shek Kok, Tai Po, N.T.  
Hong Kong

Tel: (852) 2 191 3830  
Fax: (852) 2 389 5803

Data sheets are for initial product selection and comparison. Contact Esterline Power Systems prior to choosing a component.

\* For detail SSPC information refer to EPM-109, EPM-110, and EPM-111 datasheet.

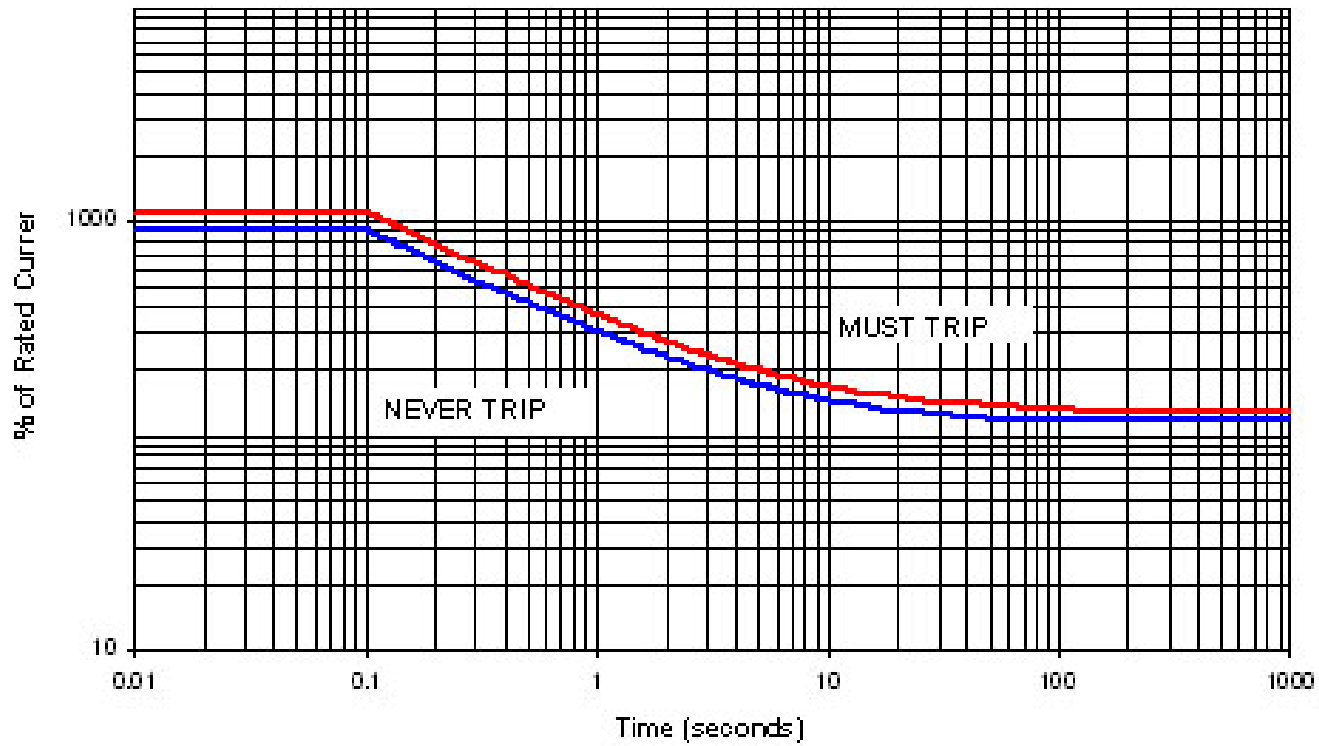

**ENVIRONMENTAL DATA**

Parameter	Symbol	Min.	Max.	Unit
Operational Temp. Range	T <sub>OP</sub>	-55	+71	°C
Storage Temp. Range	T <sub>ST</sub>	-55	+125	°C
Vibration	0.003 G <sup>2</sup> /Hz, 10-2000 Hz			
Acceleration	20 g			
Shock	10 g, 11 ms RMS			
MTBF	Typically 20,000			hr

**APPLICATION CONSIDERATION**

<ul style="list-style-type: none"> <li>● Power-On self BIT (e.g. Trip curve verification from end-to-end)</li> <li>● Continual self monitoring BIT</li> <li>● Initiated self test BIT</li> </ul>	<ul style="list-style-type: none"> <li>● Data bus contains load current information, switch status and health and status information.</li> </ul>
--	--

**PART NUMBERS****SPDU SERIES**

<b>Part Number</b>	<b>Description</b>	
PDA-125	28 Channels, 28 VDC, 6 Channels of 10A, 22 Channels of 5A, 2 ARINC 485 Databus. 2 5VDC Power Supply Boards.	
PDA-126	28 Channels, 28 VDC, 6 Channels of 10A, 22 Channels of 5A, 2 ARINC 485 Databus, 2 5VDC Power Supply Boards, Capability for discrete control.	
PDA-127	30 Channels, 28 VDC, 6 Channels of 10A, 22 Channels of 5A, 2 ARINC 485 Databus, 2 5VDC Power Supply Boards, Includes EPM-111 on rear face of unit.	2 Channels of 60A
PDA-128	30 Channels, 28 VDC, 6 Channels of 10A, 22 Channels of 5A, 2 ARINC 485 Databus, 2 5VDC Power Supply Boards, Capability for discrete control, Includes EPM-111 on rear face of unit.	2 Channels of 60A
PDA-129	28 Channels, 28 VDC, 6 Channels of 10A, 22 Channels of 5A, 2 ARINC 429 Databus. 2 5VDC Power Supply Boards.	
PDA-130	28 Channels, 28 VDC, 6 Channels of 10A, 22 Channels of 5A, 2 ARINC 429 Databus, 2 5VDC Power Supply Boards, Capability for discrete control.	
PDA-131	30 Channels, 28 VDC, 6 Channels of 10A, 22 Channels of 5A, 2 ARINC 429 Databus, 2 5VDC Power Supply Boards, Includes EPM-111 on rear face of unit.	2 Channels of 60A
PDA-132	30 Channels, 28 VDC, 6 Channels of 10A, 22 Channels of 5A, 2 ARINC 429 Databus, 2 5VDC Power Supply Boards, Capability for discrete control, Includes EPM-111 on rear face of unit.	2 Channels of 60A
PDA-133	28 Channels, 28 VDC, 6 Channels of 10A, 22 Channels of 5A, 2 CAN Databus. 2 5VDC Power Supply Boards.	
PDA-134	28 Channels, 28 VDC, 6 Channels of 10A, 22 Channels of 5A, 2 CAN Databus, 2 5VDC Power Supply Boards, Capability for discrete control.	
PDA-135	30 Channels, 28 VDC, 6 Channels of 10A, 22 Channels of 5A, 2 CAN Databus, 2 5VDC Power Supply Boards, Includes EPM-111 on rear face of unit.	2 Channels of 60A
PDA-136	30 Channels, 28 VDC, 6 Channels of 10A, 22 Channels of 5A, 2 CAN Databus, 2 5VDC Power Supply Boards, Capability for discrete control, Includes EPM-111 on rear face of unit.	2 Channels of 60A

PHYSICAL DATA

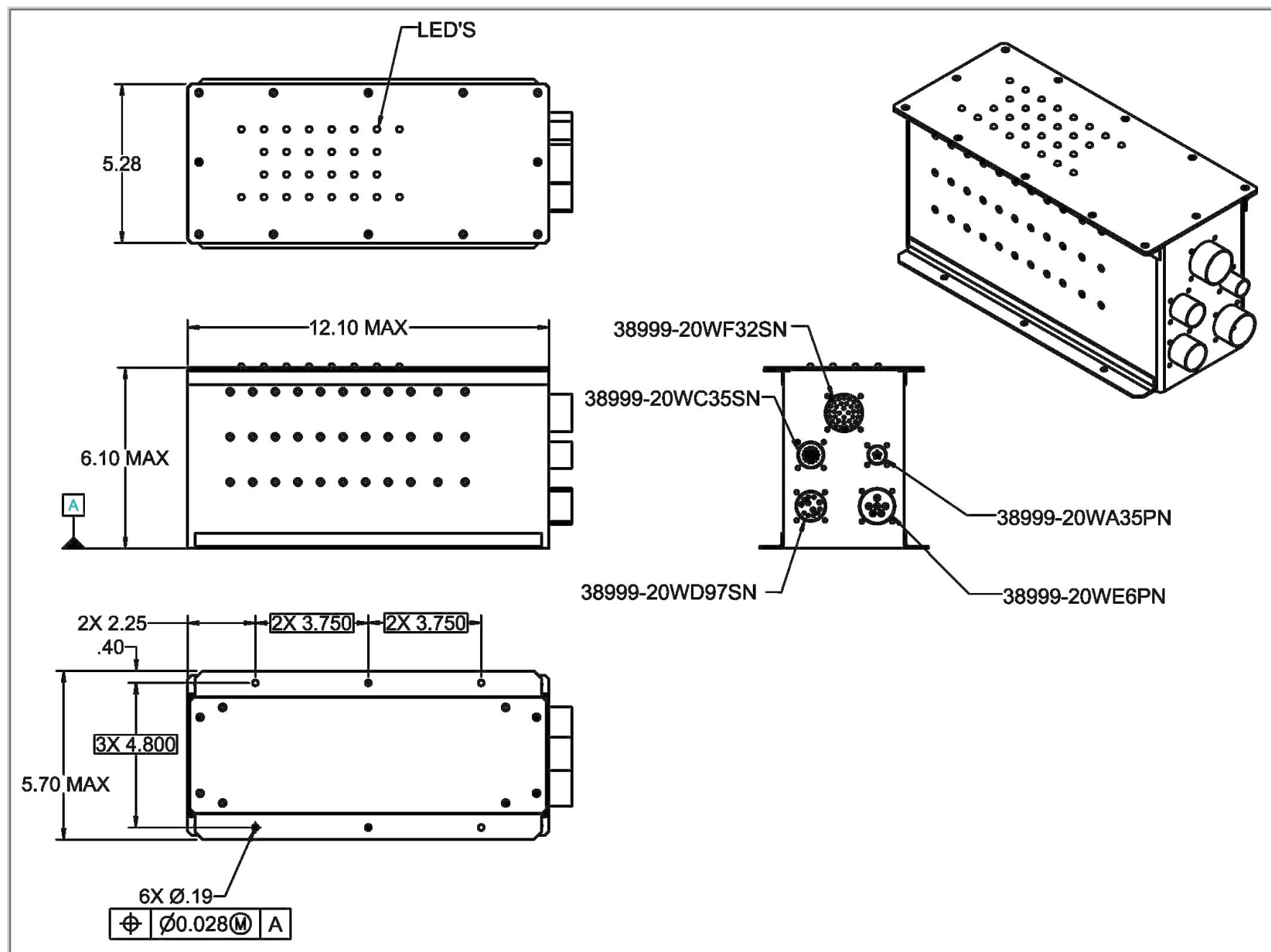

PHYSICAL DATA, with optional high current rear face unit

