

ENGINEERING DATA SHEET

T531

TIME DELAY RELAY 3 PDT, 25 AMP



Time delay relay on operate or on release

Fixed or adjustable timing delay

Contact arrangement **3 PDT**
Power supply **28 Vdc**

PRINCIPLE TECHNICAL CHARACTERISTICS

Contacts rated at **25 Amps / 28 Vdc**
Weight **<0.265lb**
Dimensions of case **1.73in x 1.54in x 1.02in max**

Hermetically sealed corrosion protected metal can (mounting flange tin plated)

APPLICABLE SOCKET:
[SO-1058-8913](#)

CONTACT ELECTRICAL CHARACTERISTICS

Minimum operating cycles	Contact rating per pole and load type	Load Current in Amps @28Vdc
50,000 cycles	on resistive load	25
10,000 cycles	on inductive load (L/R=5ms)	12
50,000 cycles	on motor load	10
50,000 cycles	on lamp load	5
50 cycles	resistive overload	50

NUMBERING SYSTEM

	T531	-	A	E	-	1001	-	B
Basic series designation	_____							
1-Types Of Operation (A,B,D,U,W)	_____							
2-Temperature range and timing accuracy (E,L,M,J,K,N)	_____							
3-Timing range (4 digits)	_____							
4-Mounting style and terminal types (B,C,D)[3]	_____							



Featuring **LEACH**® power and control solutions
www.esterline.com

AMERICAS
6900 Orangethorpe Ave.
P.O. Box 5032
Buena Park, CA 90622

Tel: (01) 714-736-7599
Fax: (01) 714-670-1145

EUROPE
2 Rue Goethe
57430 Sarralbe
France

Tel: (33) 3 87 97 31 01
Fax: (33) 3 87 97 96 86

ASIA
Units 602-603 6/F Lakeside 1
No.8 Science Park West Avenue
Phase Two, Hong Kong Science Park
Pak Shek Kok, Tai Po, N.T.
Hong Kong

Tel: (852) 2 191 3830
Fax: (852) 2 389 5803

Data sheets are for initial product selection and comparison. Contact Esterline Power Systems prior to choosing a component.

CODE A : TIME DELAY ON OPERATE,
FIXED TIME

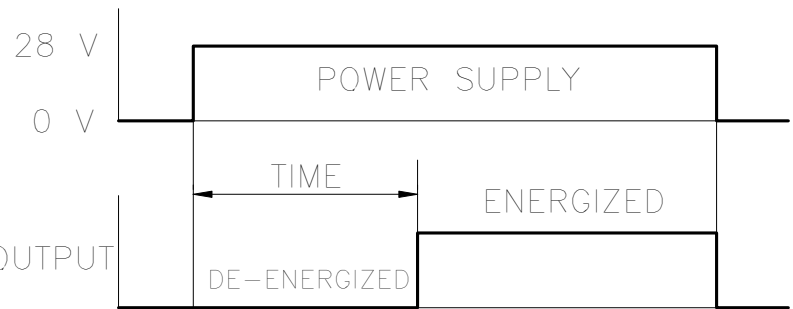

CODE B : TIME DELAY ON OPERATE,
ADJUSTABLE WITH EXTERNAL RESISTOR

CODE D : TIME DELAY ON RELEASE,
POSITIVE CONTROL, FIXED TIME

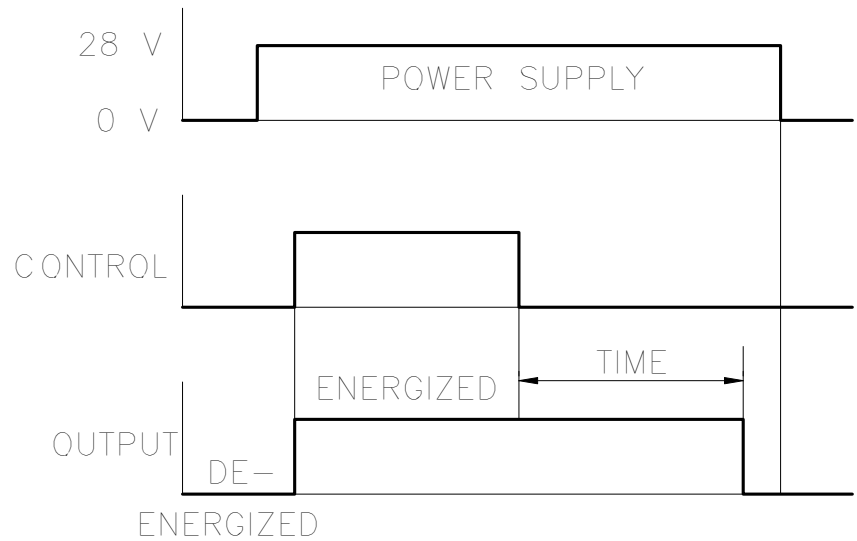

CODE U : TIME DELAY ON RELEASE,
FIXED TIME

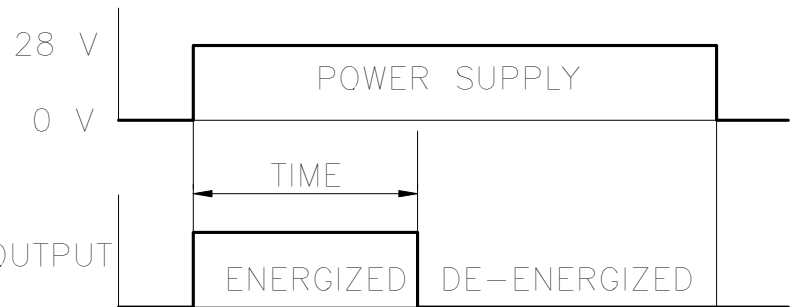

CODE W : TIME DELAY ON RELEASE,
ADJUSTABLE WITH EXTERNAL RESISTOR

TEMPERATURE RANGE AND TIMING ACCURACY

Code	Temperature	Accuracy	Limitations
E	-55° C to +85° C	±10%	±10 ms below 200 ms
L [4]	-55° C to +85° C	±5%	not below 500 ms
M [4]	-55° C to +85° C	±3%	not below 1 s
J [4]	-55° C to +125° C	±10%	±10 ms below 200ms
K [4]	-55° C to +100° C	±5%	not below 500 ms
N [4]	-55° C to +100° C	±3%	not below 1 s

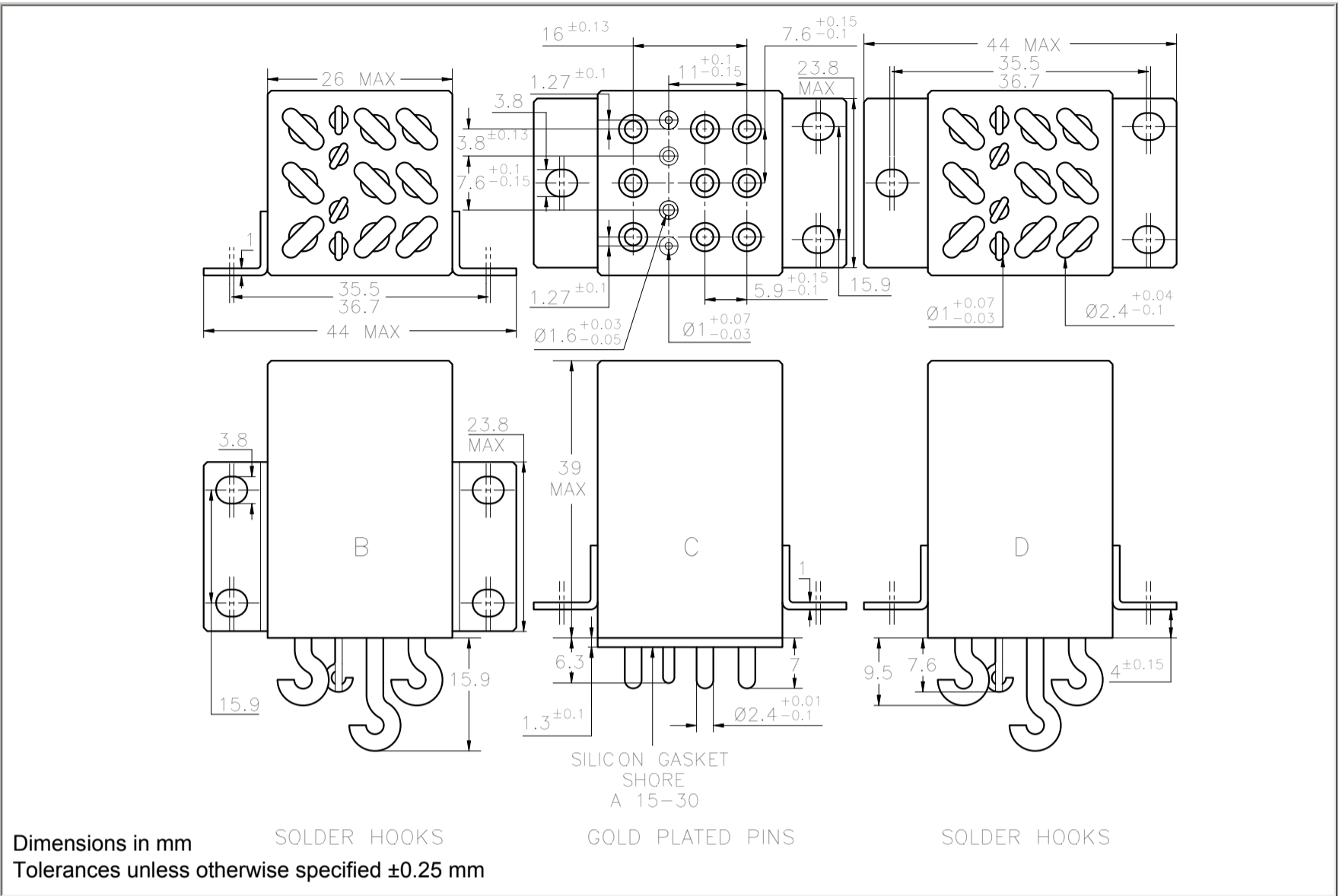

SCHEMATIC DIAGRAM/TERMINAL LAYOUT

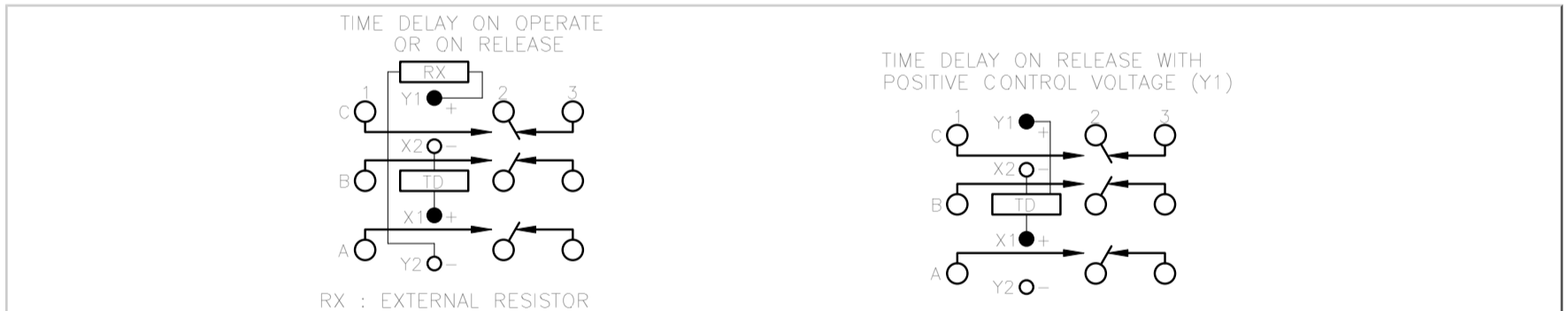

TIMING RANGE

ADJUSTABLE

(For operation code B, F and W)

- Code 1001: 0.1 to 1 second $R_x = (T / t_0 - 1) \times 100\text{kohm}$
- Code 1002: 1 to 10 seconds
- Code 1003: 10 to 100 seconds
- Code 1004: 100 to 1000 seconds where R_x in kohms T: desired time in seconds,

t_0 : time measured with $R_x = 0$.

Example to determine R_x value for a T time of 5 seconds: Choose code 1002; measure time with $R_x = 0$ (for example : $t_0 = 1$ s); calculate $R_x = (5/1 - 1) \times 100000$
Theoretical resistance: $R_x = 400$ kohms

FIXED

The timing code consists of 4 digits. To determine this code, convert the value to milliseconds value. Use the first 3 digits of this value and add a fourth digit to indicate the number of zeros which must follow the three digits to show complete milliseconds value.

Examples: 250 ms --> Code 2500 300 s --> Code 3003

GENERAL CHARACTERISTICS**T531**

Operating Voltage	18 to 32 Vdc (AIR norm 2021 E)
Recycle Time	less than or equal to 50 ms
Dielectric strength at sea level	
- all pins connected together and can	500 V / 50 Hz
- between open contacts	500 V / 50 Hz
Dielectric strength at altitude 80,000 ft, all points	250 V / 50 Hz
Initial insulation resistance at 500 Vdc	greater than or equal to 500 M Ω
Sinusoidal vibration	20G / 10 to 2000 Hz
Shock	100G / 6 ms
Power loss protection	0.5 ms max
Undamaged against positive transients	+ 80 Vdc
Spike susceptibility	\pm 600 Vdc
Self generated spikes	\pm 50 Vdc

NOTES

1. Relays with C mounting are compatible with socket families S 502, SF 502 ..
2. Isolation spacer pads for PCB mounting available on request.
3. For other mounting styles or terminal types, please contact the factory.
4. Codes L, M, K and N not available for adjustable timing.

ENGINEERING DATA SHEET

SO-1058-8913

RELAY SOCKET
25 AMP



BASIC SOCKET SERIES DESIGNATION FOR:

Series KCL and T531

DESIGNED TO THE STANDARDS AND REQUIREMENTS OF:

MIL-S-12883/54

SOCKET DRAWING

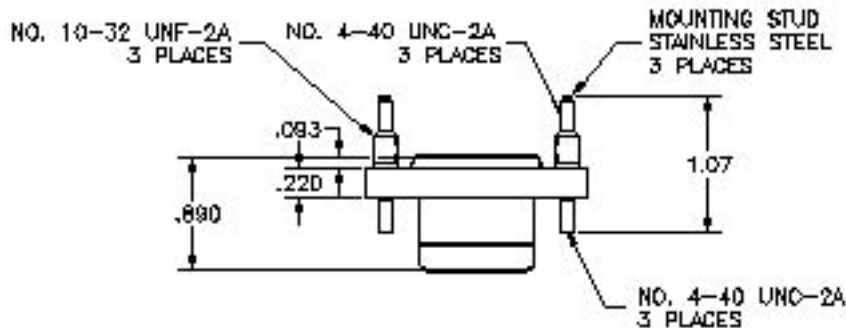
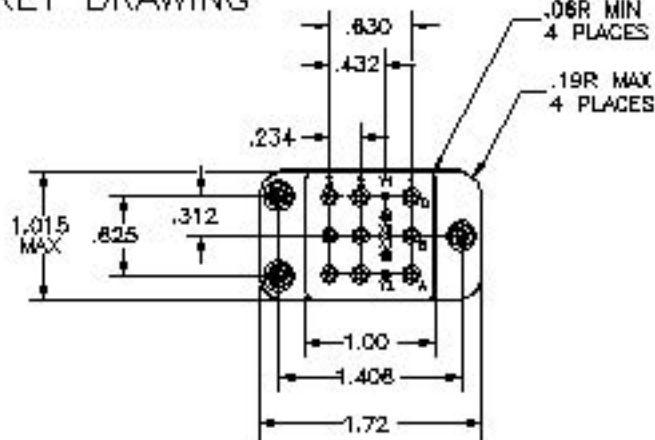

HARDWARE MOUNTING

MOUNTING DETAIL 3 PLACES

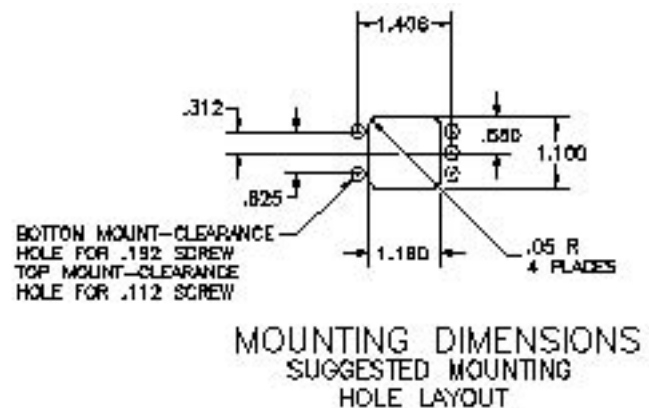
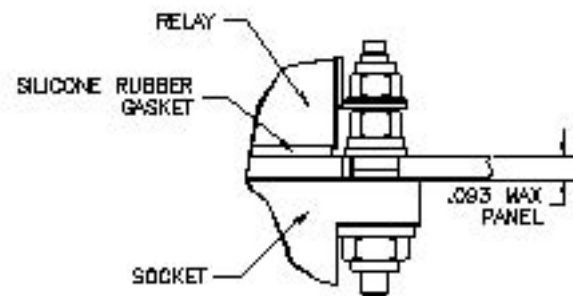

GENERAL CHARACTERISTICS

1. Supplied with mounting hardware No. 12, 16 and 20 contacts, No. 12, 16 and 20 crimps.

2. Standard tolerances

.xx ±.01; xxx ±.005

3. Weight

.120 lb. max

4. Temperature range

-70° C to +125° C



Featuring **LEACH**® power and control solutions

www.leachintl.com

Data sheets are for initial product selection and comparison. Contact Leach International prior to choosing a component.

AMERICAS

6900 Orangethorpe Ave.
P.O. Box 5032
Buena Park, CA 90622 USA

Tel: (01) 714-736-7599

Fax: (01) 714-670-1145

EUROPE

2 Rue Goethe
57430 Sarralbe
France

Tel: (33) 3 87 97 31 01

Fax: (33) 3 87 97 96 86

ASIA

Room 501, 5/F, The Centre Mark
287 - 299 Queen's Road Central
Hong Kong

Tel: (852) 2 191 3830

Fax: (852) 2 389 5803