

ENGINEERING DATA SHEET

SERIES ZE-X9YN

SMART, PLUG-IN CONTACTOR
3 PST/NO, 60 AMP



Electrical Load Control Unit (ELCU)

Balanced-Force design

Designed to the performance standards of

MIL-PRF-6106

Contact arrangement

3 PST/NO

PRINCIPLE TECHNICAL CHARACTERISTICS

Contacts rated at

115/200, 400Hz, 3Ø

Weight

2.75lbs max

Dimensions

3.36 in. x 3.36 in. x 5.00 in.

Special units available upon request, including models with auxiliary contacts.

CONTACT ELECTRICAL CHARACTERISTICS

Contact rating per pole and load type	Load current in Amps
	115/200 Vac, 400 Hz, 3Ø
Resistive	60
Inductive	60
Motor	38



Featuring **LEACH**® power and control solutions
www.esterline.com

AMERICAS
6900 Orangethorpe Ave.
P.O. Box 5032
Buena Park, CA 90622

Tel: (01) 714-736-7599
Fax: (01) 714-670-1145

EUROPE
2 Rue Goethe
57430 Sarralbe
France

Tel: (33) 3 87 97 31 01
Fax: (33) 3 87 97 96 86

ASIA
Units 602-603 6/F Lakeside 1
No.8 Science Park West Avenue
Phase Two, Hong Kong Science Park
Pak Shek Kok, Tai Po, N.T.
Hong Kong
Tel: (852) 2 191 3830
Fax: (852) 2 389 5803

Data sheets are for initial product selection and comparison. Contact Esterline Power Systems prior to choosing a component.

COIL CHARACTERISTICS (Vdc)**SERIES ZE-X9YN**

Nominal operating voltage	28 Vdc
Pick-up voltage	15 Vdc
Drop-out voltage	1.5 to 7 Vdc
Maximum pick-up time	25 ms
Maximum drop-out time	15 ms
Maximum pick-up current	4 Amp for 1 sec max
Maximum hold current	.25 Amp

GENERAL CHARACTERISTICS

Contact Data	Main Contacts
-Configuration	3PST NO
-Supply voltage	115/200 Vac
-Continuous current	60 Amp at .85PF
-Rupture current	1600 Amp
-Overload	800 Amp
-Maximum contact bounce	3 ms
-Simultaneous operation	3 ms
-Short circuit current	2200 Amp RMS, once
Electrical life	
-At ambient pressure	25,000 operations
-At 45,000 ft	25,000 operations
Mechanical life	100,000 operations
Altitude	45,000 ft
Continuous operating temperature range	-15°C to +65°C

NUMBERING SYSTEM

	ZE-X2YN - XXX
Basic series designation_____	
Customer configuration_____	

CONFIGURATION

ZE-X9YN

Position	Pin	Function
1	+28 Vdc	Power supply for the device
2	DC return	28 Vdc power supply return
3	CMD	Control signal for contactor. [1]
4 thru 7	N/C	Contactor status
8 thru 10	I_PHA, I_PHB, I_PHC	Current input pins
11	0V	Ground reference
12 thru 13	Latch status	Signal line reporting the load current condition
14 thru 15	N/C	Contactor status

[1] A low-level signal commands contactor to close

TYPICAL SCHEMATIC

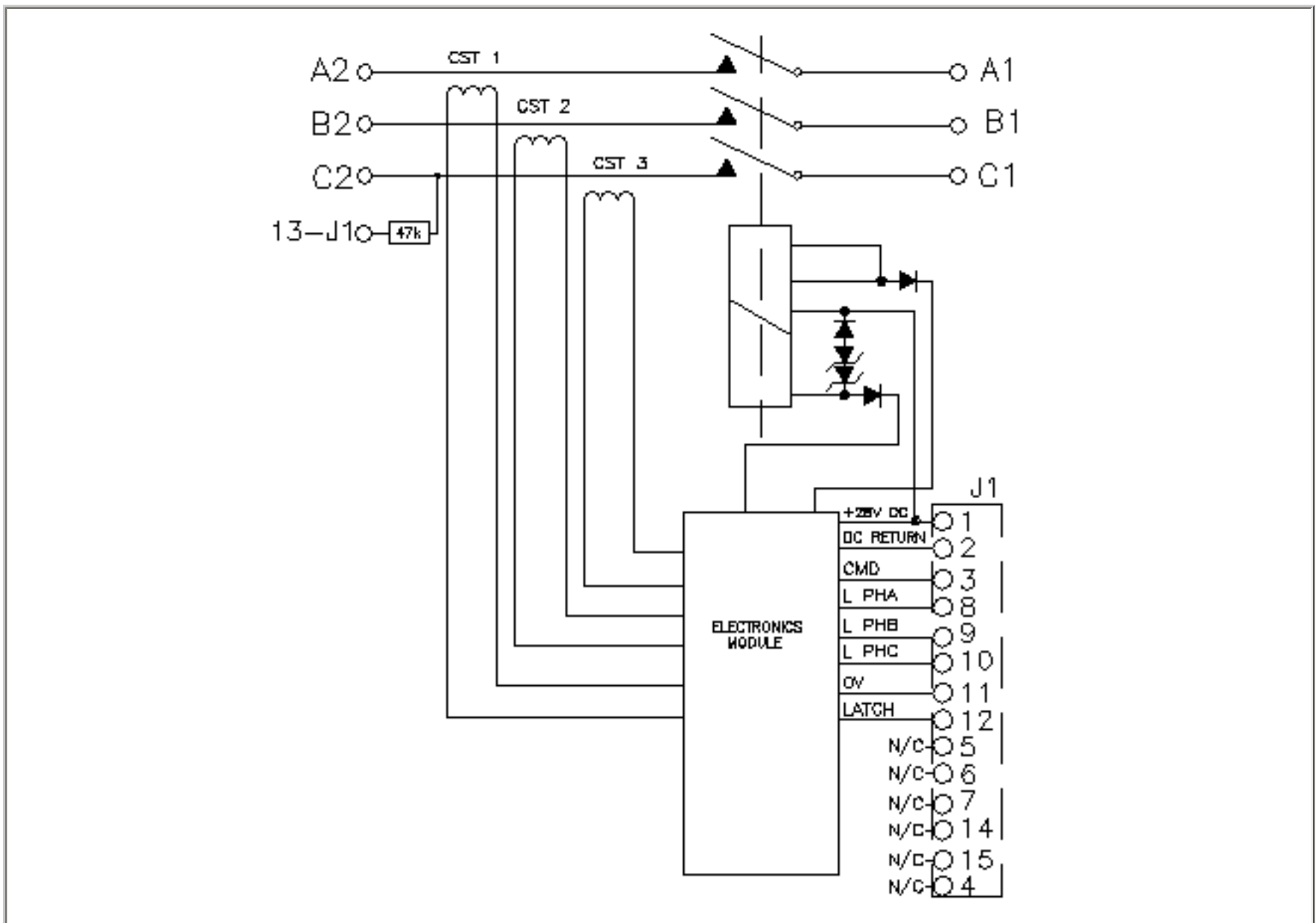

POWER ON/RESET

Normal conditions	18 to 32 Vdc
Operating current at 28 Vdc	100 mAmp max, contactor "open"
	350 mAmp max, contactor "closed"

CMD

High level	Min 7 to 10.5 Vdc
Low level	Min 3 to 7.4 Vdc
Input hysteresis	1.3 to 4.3 Vdc
Pull-up resistor	10 K Ω +/- 1%
Input capacitance	<125nF
Input current	<200 μ Amp at 28 Vdc

TRIP LEVEL PROGRAMMABILITY

Current status	Phase A, B, C
Frequency PWM output	666.7 Hz, +/- 3%
Low level duty cycle	25% to 40%
High level duty cycle	60% to 75%
Signal amplitude	7.5 to 16.5 Vdc
Rise Time	20 to 100 μ sec
Output resistance	4 K Ω nominal

LATCH STATUS

High Level	>100 K Ω to 28 Vdc
Low Level	<100 Ω to DC return

CONTACTOR STATUS

Contactor closed	115/200 Vac, 400 Hz, typical via 47 K Ω resistor
Contactor open	Open circuit

CONTROL LOGIC SPECIFICATION

Undervoltage trip	Contactor control logic will initiate a trip within 25ms if 28 VDC supply drops below 20 Vdc while load current is equal to or above 460 Amp +/- 6%. The contactor will remain in the open state until a reset command sequence is provided.
Over current trip	Contactor control logic will initiate a trip if load current exceeds the I ² t trip curve. The contactor will remain in the open state until a reset command sequence is provided.
Reset command	The contactor clears, from the latched state, by removing 28 Vdc power (open circuit) for a period greater than or equal to 250 ms. The contactor resets by removing CMD input (open circuit) for a period greater than or equal to 5 ms.
Undervoltage lockout	The control logic shall command open and the ELCU shall de-energize within 50 ms of the 28 Vdc power supply dropping to less than 9.5 Vdc. The control logic shall maintain all functions when the 28 Vdc power supply is between 10 to 18 Vdc.

