

**APPLICATION NOTES:**

- [001](#)
- [002](#)
- [103B](#)
- [007](#)

**APPLICABLE SOCKET:**

[SO-1064-10534](#)

All welded construction

Contact arrangement **1 PDT**

Designed to the performance standards of **MIL-PRF-83536**

**PRINCIPLE TECHNICAL CHARACTERISTICS**

Contacts rated at **Low level, 28 Vdc and 115/200 Vac, 400Hz, 3Ø, case grounded**

Weight **0.034lb max**

Dimensions **.41in x .81in x .64in**

Special units available upon request.  
 Hermetically sealed, corrosion resistant metal can.

**CONTACT ELECTRICAL CHARACTERISTICS**

Contact rating per pole and load type [1]	Load current in Amps	
	@28 Vdc	@115 Vac, 400 Hz, 1Ø
Resistive	10	10
Inductive [2]	6	8
Motor	4	4
Lamp	2	2
Overload	30	60
Rupture	32	80
Low level [3]	-	-
Time current characteristics [4]	-	-



**Leach International**  
[www.leachintl.com](http://www.leachintl.com)

**North America**  
 6900 Orangethorpe Ave.  
 P.O. Box 5032  
 Buena Park, CA 90622 USA

Tel: (01) 714-736-7599  
 Fax: (01) 714-670-1145

**Europe, SA**  
 2 Rue Goethe  
 57430 Sarralbe  
 France

Tel: (33) 3 87 97 98 97  
 Fax: (33) 3 87 97 84 04

**Asia-Pacific Ltd.**  
 20/F Shing Hing Commercial Bldg.  
 21-27 Wing Kut Street  
 Central, Hong Kong

Tel: (852) 2 191 2886  
 Fax: (852) 2 389 5803

Data sheets are for initial product selection and comparison. Contact Leach International prior to choosing a component.

**COIL CHARACTERISTICS (Vdc)****SERIES XCL**

CODE	A	B	C	N [5]	R [5]	V [5]
Nominal operating voltage	28	12	6	28	12	6
Maximum operating voltage	29	14.5	7.3	29	14.5	7.3
Maximum pickup voltage						
- Cold coil at +125° C	18	9	4.5	18	9	4.5
- During high temp test at +125° C	19.8	9.9	5	19.8	9.9	5
- During continuous current test at +125° C	22.5	11.25	5.7	22.5	11.25	5.7
Maximum drop-out voltage	7	4.5	2.5	7	4.5	2.5
Coil resistance in $\Omega$ $\pm 10\%$ at +25° C except types "C" & "V" +20%, -10%	730	182	43	730	182	43

**GENERAL CHARACTERISTICS**

Temperature range	-70°C to +125°C
Minimum operating cycles (life) at rated load	50,000
Minimum operating cycles (life) at 25% rated load	200,000
Dielectric strength at sea level - All circuits to ground and circuit to circuit	1000 Vrms
Dielectric strength at sea level - Coil to ground	1000 Vrms
Dielectric strength at altitude 80,000 ft	500 Vrms [6]
Insulation resistance - Initial (500 Vdc)	100 M $\Omega$ min
Insulation resistance - After environmental tests (500 Vdc)	50 M $\Omega$ min
Sinusoidal vibration (A, D and J mounting)	0.12DA / 10 to 70 Hz 30G / 70 to 3000 Hz
Sinusoidal vibration (G mounting)	0.12DA / 10 to 57 Hz 20G / 57 to 3000 Hz
Random vibration	
- Applicable specification	MIL-STD-202
- Method	214
- Test condition - A, D and J mounting	1G (0.4G <sup>2</sup> /Hz, 50 to 2000 Hz)
- Test condition - E and G mounting (E in track)	1E (0.2G <sup>2</sup> /Hz, 50 to 2000 Hz)
- Duration	15 minutes each plane
Shock (A, D and J mounting)	200G / 6 ms
Shock (G mounting)	100G / 6 ms
Maximum contact opening time under vibration and shock	10 $\mu$ s
Operate time at nominal voltage@25°C	6 ms max
Release time at nominal voltage@25°C	6 ms max
Contact make bounce at nominal voltage@25°C	1 ms max
Contact release break bounce at nominal voltage@25°C	0.5 ms max [7]
Weight maximum	0.034lb

Unless otherwise noted, the specified temperature range applies to all relay characteristics.

- [1] Standard Intermediate current test applicable.
- [2] Inductive load life, 20,000 cycles. AC; 10,000 cycles DC.
- [3] Low level endurance test: contact load of 10 to 50 millivolt, 10 to 50 microamp, 100 Ohm max. contact resistance.
- [4] Refer to MIL-R-83536 for details.
- [5] "N" "R" & "V" coils have back EMF suppression to 42 volts maximum.
- [6] 500 Vrms with silicone rubber gasket compressed, 250 Vrms all other conditions.
- 7. Applicable to Type "N", "R" & "V" coils only.
- 8. Relay will not operate, but will not be damaged by application of reverse polarity on coil.

**NUMBERING SYSTEM**

	XCL	A	1	A
Basic series designation _____				
1-Mounting Style (A,D,E,G,J) _____				
2-Terminal Types (1,2,4 & 7) _____				
3-Coil Voltage see coil characteristics (A,B,C,N,R or V) _____				

**MOUNTING STYLES**

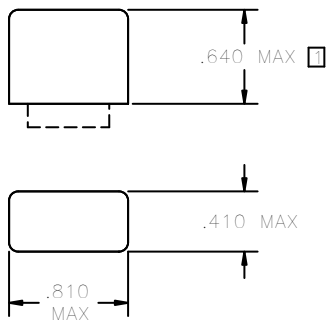

RELAY HEIGHT MAY BE INCREASED .100 INCH FOR "N" SUPPRESSED COILS  
MOUNTING STYLE A

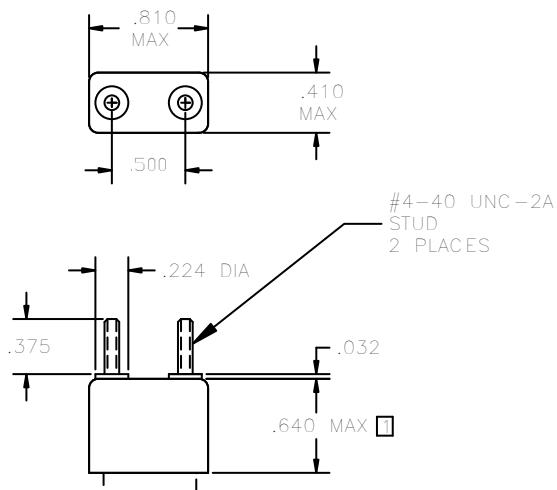

RELAY HEIGHT MAY BE INCREASED .100 INCH FOR "N" SUPPRESSED COILS  
MOUNTING STYLE G

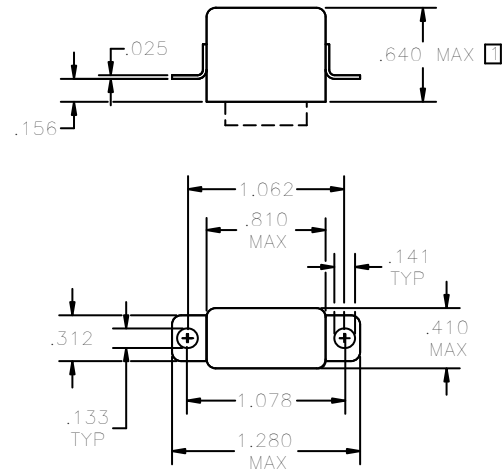

RELAY HEIGHT MAY BE INCREASED .100 INCH FOR "N" SUPPRESSED COILS  
MOUNTING STYLE D

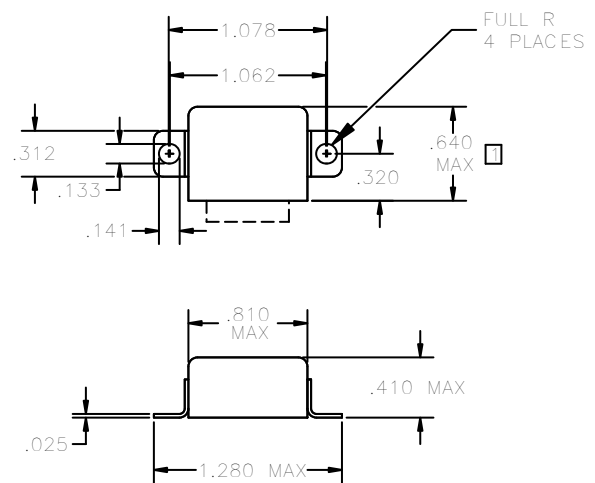

RELAY HEIGHT MAY BE INCREASED .100 INCH FOR "N" SUPPRESSED COILS  
MOUNTING STYLE J

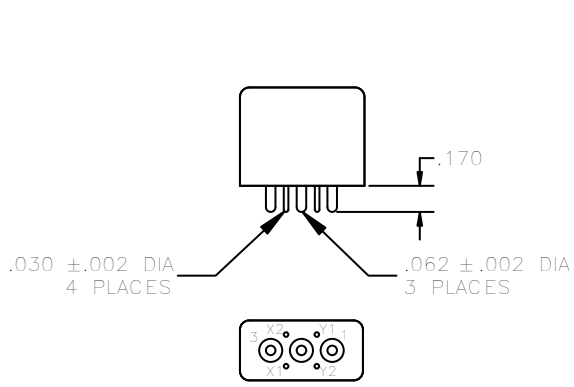

TERMINAL TYPE 1

FINISH:  
BODY-LEACH BLUE  
TERMINALS-TIN/LEAD

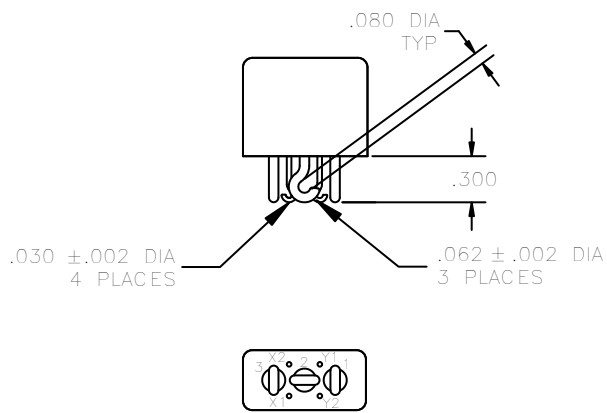

TERMINAL TYPE 2

FINISH:  
BODY-LEACH BLUE  
TERMINALS-TIN/LEAD

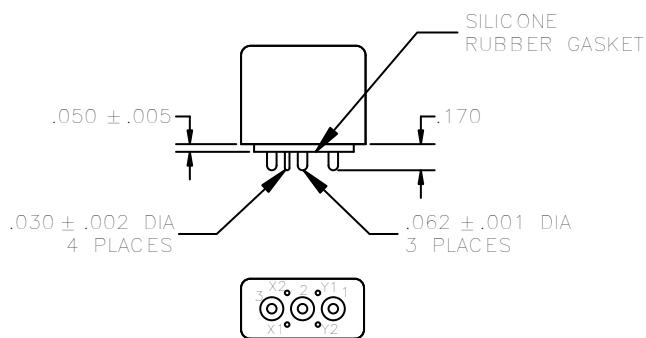

TERMINAL TYPE 4

FINISH:  
BODY-LEACH BLUE  
TERMINALS-GOLD PLATED  
POLARIZING PIN-TIN/LEAD

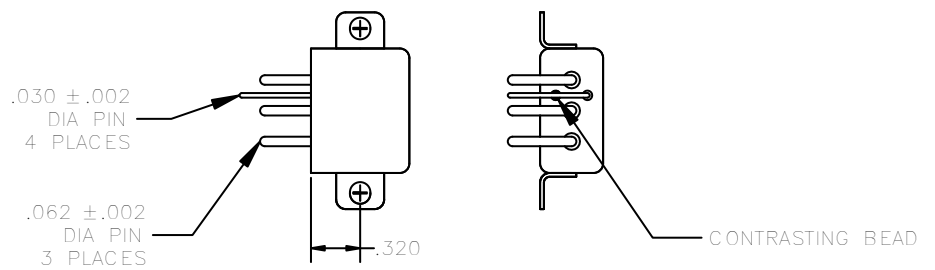

TERMINAL TYPE 7

FINISH:  
BODY - LEACH BLUE  
TERMINALS - TIN/LEAD

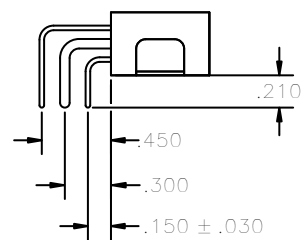

SCHEMATIC DIAGRAM

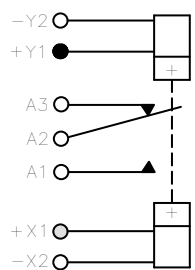

WIRING DIAGRAM

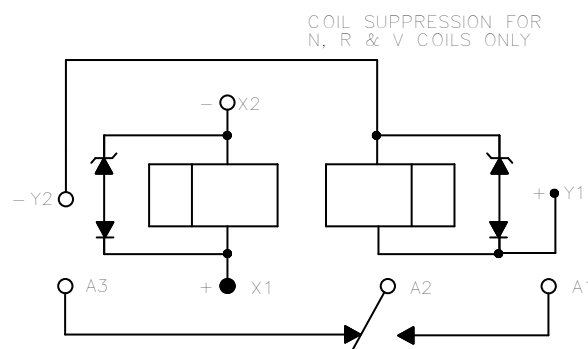

STANDARD TERMINAL LAYOUT

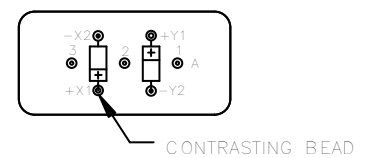

TOL: .XX ±.03; .XXX ±.010

Note: Although all configuration and / or terminal type options are available, some combinations may require a setup charge and be subject to minimum order size.

**CORRECTION DUE TO COIL COPPER WIRE RESISTANCE  
CHANGE IN TEMPERATURE**

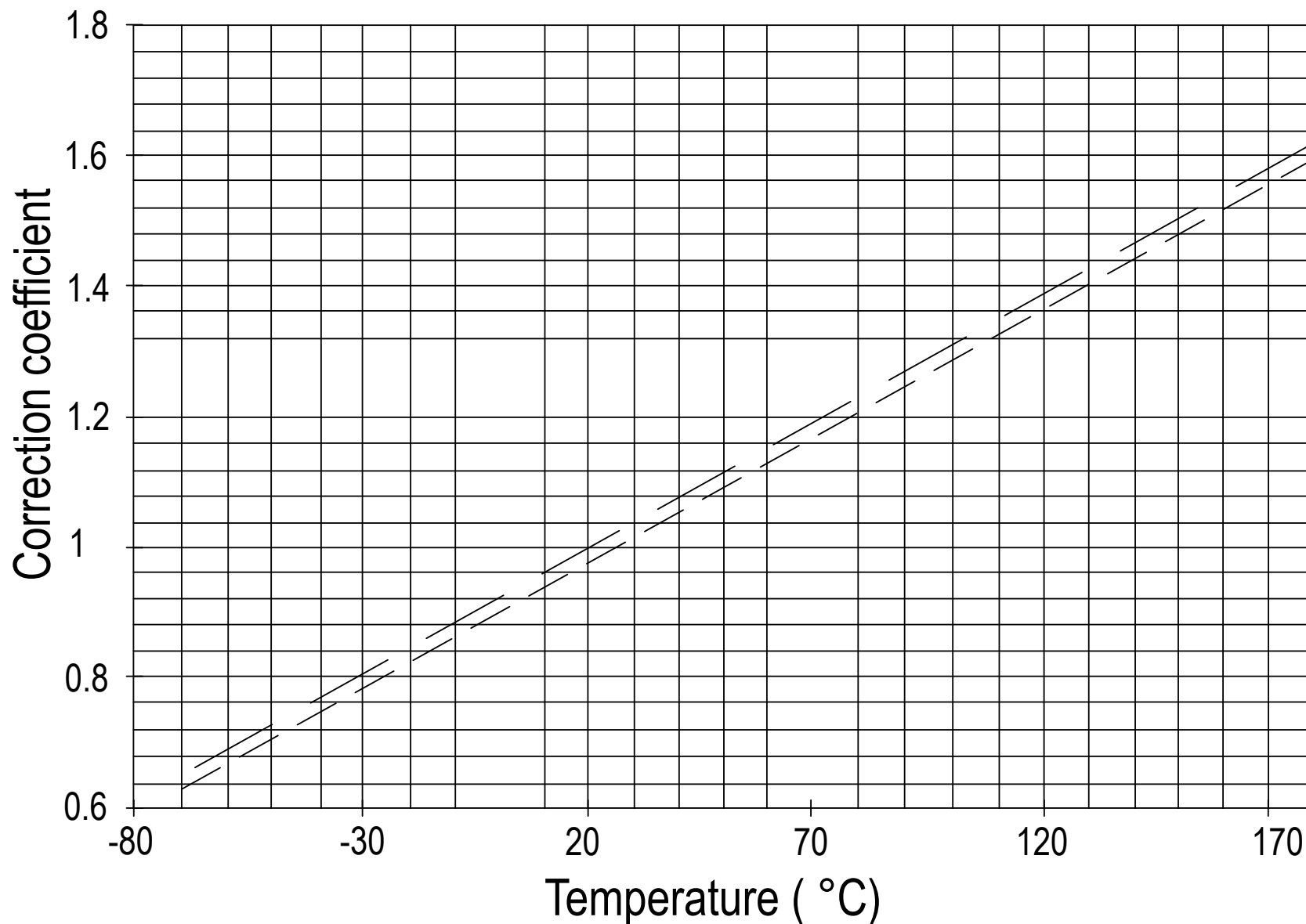

— — Nominal Resistance at 25°C

———— Nominal Resistance at 20°C

Example: Coil resistance at 25°C: 935 ohms. What is it at 125°C?

Correction coefficient on diagram is: 1.39 at 125°C. R becomes:  $935 \times 1.39 = 1299$  Ohms

Correction also applies to operating voltages

### LIFE CAPABILITY VERSUS VOLTAGE

Relay Series F/M30\*, 40\*, 60\*

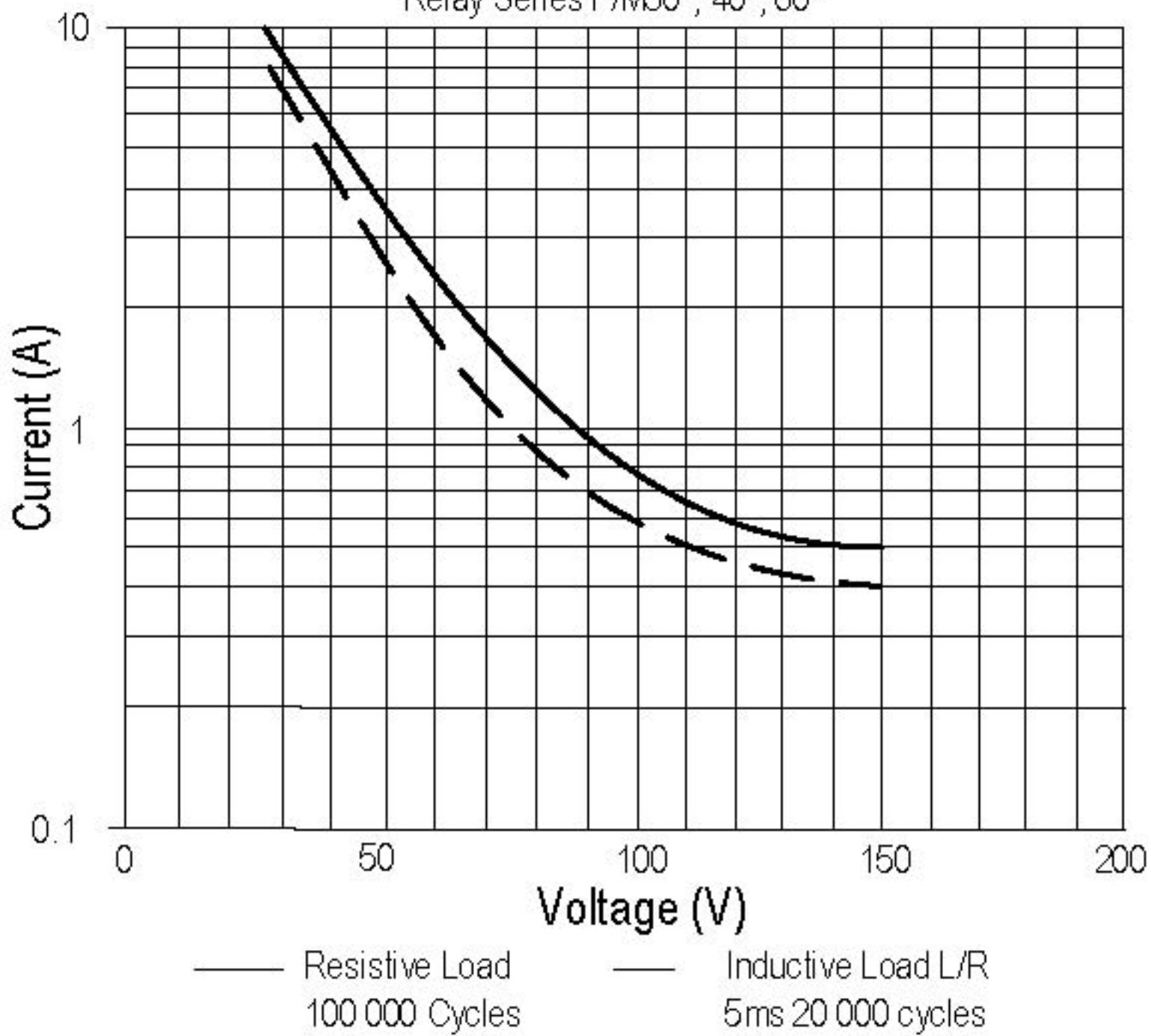

**LIFE CAPABILITY VERSUS VOLTAGE**

Relay Series FD 30,\* 40\*, 60\*

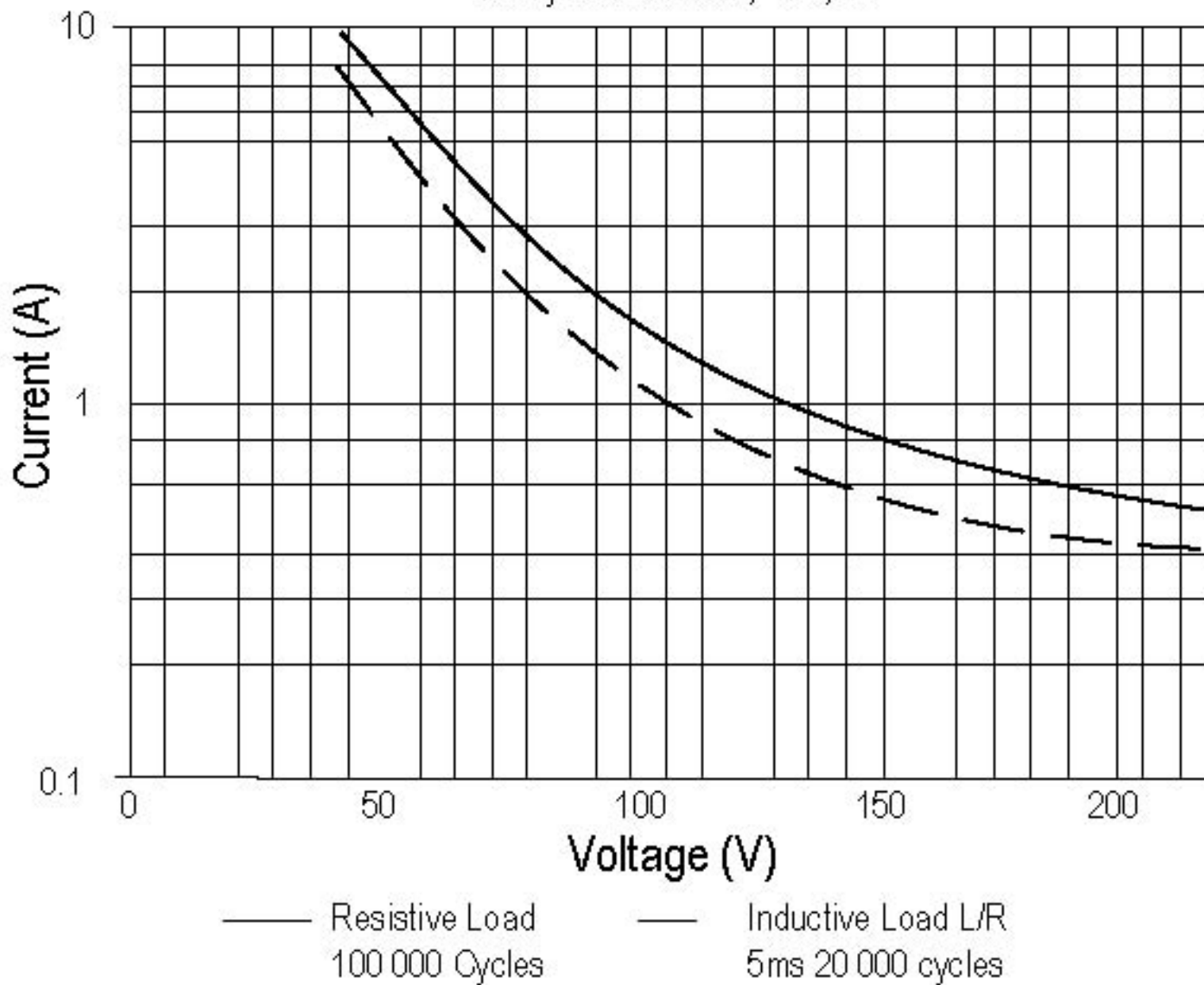

**CURVES FOR DC VOLTAGES ABOVE NORMAL RATING: RESISTIVE LOAD ONLY**  
(without arc suppression)

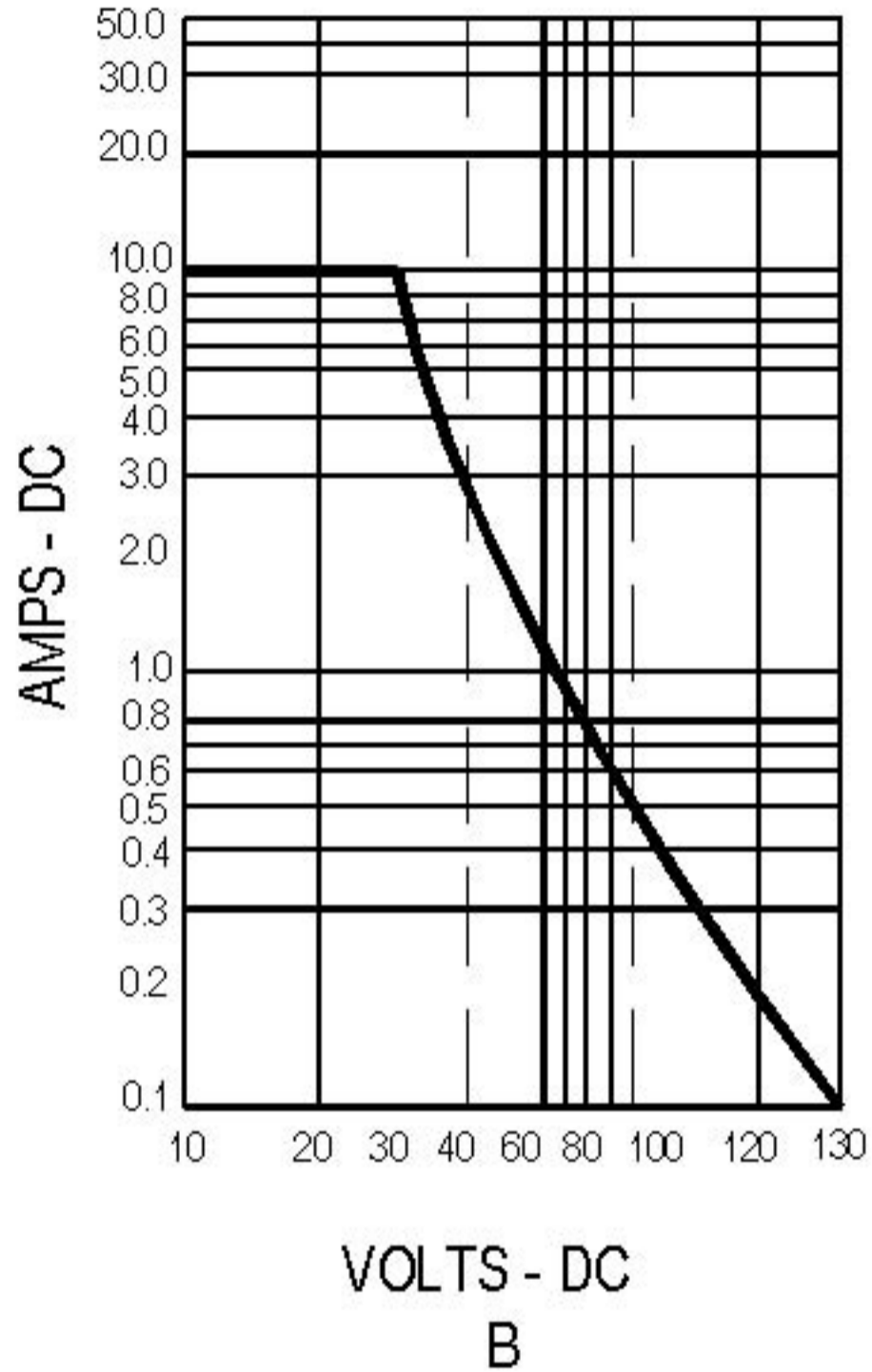

## SUPPRESSOR DEVICES FOR RELAY COILS

The inductive nature of relay coils allows them to create magnetic forces which are converted to mechanical movements to operate contact systems. When voltage is applied to a coil, the resulting current generates a magnetic flux, creating mechanical work. Upon deenergizing the coil, the collapsing magnetic field induces a reverse voltage (also known as back EMF) which tends to maintain current flow in the coil. The induced voltage level mainly depends on the duration of the deenergization. The faster the switch-off, the higher the induced voltage.

All coil suppression networks are based on a reduction of speed of current decay. This reduction may also slow down the opening of contacts, adversely effecting contact life and reliability. Therefore, it is very important to have a clear understanding of these phenomena when designing a coil suppression circuitry.

### Typical coil characteristics

On the graph below, the upper record shows the contacts state. (High level NO contacts closed, low level NC contacts closed, intermediate state contact transfer). The lower record shows the voltage across the coil when the current is switched off by another relay contact.

The surge voltage is limited to -300V by the arc generated across contact poles. Discharge duration is about 200 microseconds after which the current change does not generate sufficient voltage. The voltage decreases to the point where the contacts start to move, at this time, the voltage increases due to the energy contained in the NO contact springs. The voltage decreases again during transfer, and increases once more when the magnetic circuit is closed on permanent magnet.

Operating times are as follows:

Time to start the movement 1.5ms

Total motion time 2.3ms

Transfer time 1.4ms

Contact State

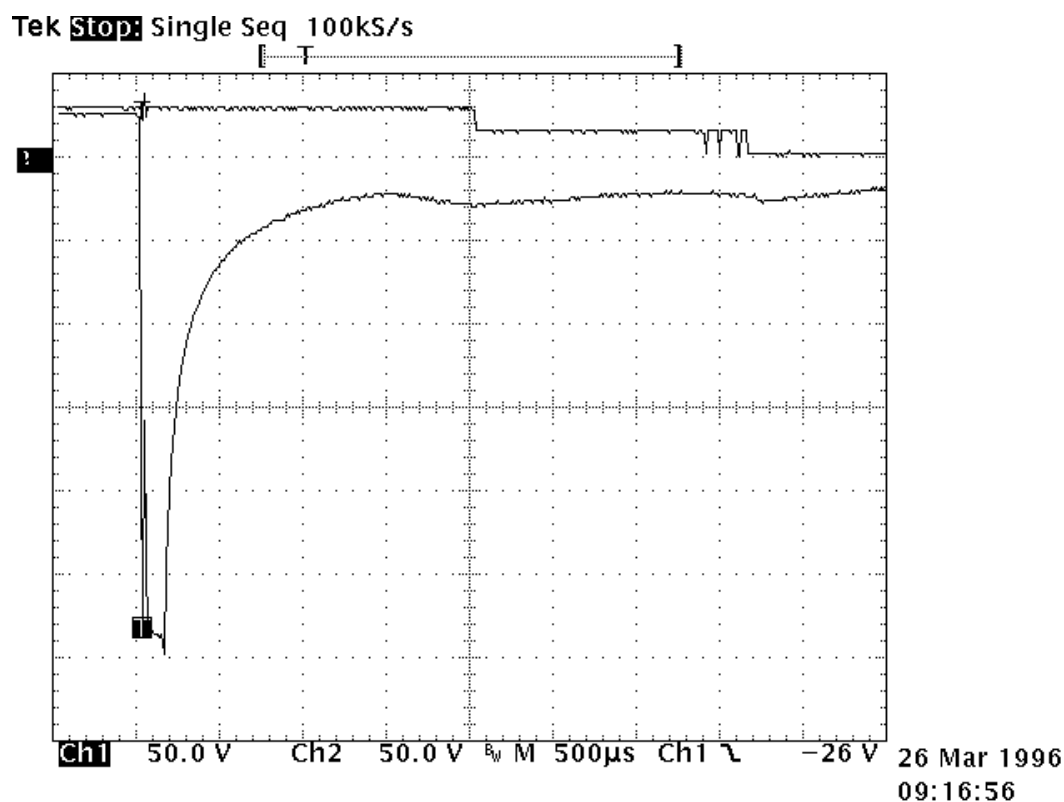

## Types of suppressors:

### Passive devices.

#### The resistor capacitor circuit

It eliminates the power dissipation problem, as well as fast voltage rises. With a proper match between coil and resistor, approximate capacitance value can be calculated from:

$C = 0.02 \times T/R$ , where

T = operating time in milliseconds

R = coil resistance in kiloOhms

C = capacitance in microFarads

The series resistor must be between 0.5 and 1 times the coil resistance. Special consideration must be taken for the capacitor inrush current in the case of a low resistance coil.

The record shown opposite is performed on the same relay as above. The operation time becomes:

- time to start the movement 2.3ms

- transfer time 1.2ms

The major difficulty comes from the capacitor volume. In our example of a relay with a  $290 \Omega$  coil and time delay of 8 ms, a capacitance value of  $C=0.5 \mu\text{F}$  is found. This non polarized capacitor, with a voltage of 63V minimum, has a volume of about  $1\text{cm}^3$ . For 150V, this volume becomes  $1.5 \text{cm}^3$ .



### The bifilar coil

The principle is to wind on the magnetic circuit of the main coil a second coil shorted on itself. By a proper adaptation of the internal resistance of this second coil it is possible to find an acceptable equilibrium between surge voltage and reduction of the opening speed. To be efficient at fast voltage changes, the coupling of two coils must be perfect. This implies embedded windings. The volume occupied by the second coil reduces the efficiency of the main coil and results in higher coil power consumption. This method cannot be applied efficiently to products not specifically designed for this purpose.

### The resistor (parallel with the coil)

For efficient action, the resistor must be of the same order of magnitude as the coil resistance. A resistor 1.5 times the coil resistance will limit the surge to 1.5 times the supply voltage. Release time and opening speed are moderately affected. The major problem is the extra power dissipated.

### **Semi-conductor devices**

#### The diode

It is the most simple method to totally suppress the surge voltage. It has the major disadvantage of the higher reduction of contact opening speed. This is due to the total recycling, through the diode, of the energy contained in the coil itself. The following measurement is performed once again on the same relay. Operation times are given by the upper curve:

- time to start the movement 14ms
- transfer time 5ms

These times are multiplied by a coefficient from 4 to 8.

The lower curve shows the coil current. The increase prior to NO contact opening indicates that the contact spring dissipates its energy. At the opening time the current becomes constant as a result of practically zero opening speed.

Due to this kind of behavior, this type of suppression must be avoided for power relays. For small relays which have to switch low currents of less than 0.2 A, degradation of life is not that significant and the method may be acceptable.



The diode + resistor network

It eliminates the inconvenience of the resistor alone, explained above, and it limits the action of a single diode. It is now preferred to use the diode + zener network.

The diode + zener network

Like the resistor, the zener allows a faster decurrent decay. In addition it introduces a threshold level for current conduction which avoids the recycling of energy released during contact movement.

The lower curve on the opposite record demonstrates those characteristics. Voltage limitation occurs at 42V. The two voltage spikes generated by internal movement are at lower levels than zener conduction. As a result, no current is recycled in the coil.

The opening time phases are as follows:

- time to start the movement 2.6ms
- total motion time 2.4ms
- transfer time 1.4ms

The release time is slightly increased. The contacts' opening speed remains unchanged.



# SO-1064-10534

## ENGINEERING DATA SHEET

RELAY SOCKET  
10 AMP



BASIC SOCKET SERIES DESIGNATION FOR:

**Series XCL**

DESIGNED TO THE STANDARDS AND REQUIREMENTS OF:

**MIL-S-12883**

### SOCKET DRAWING

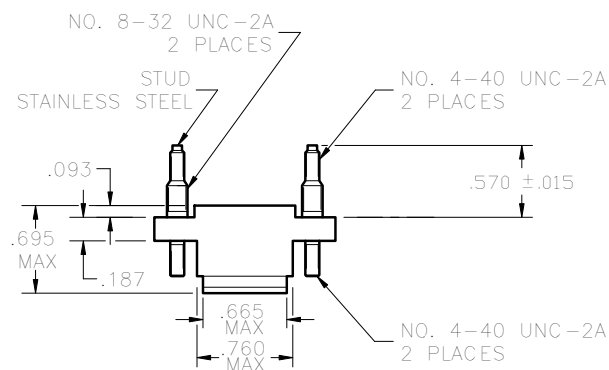
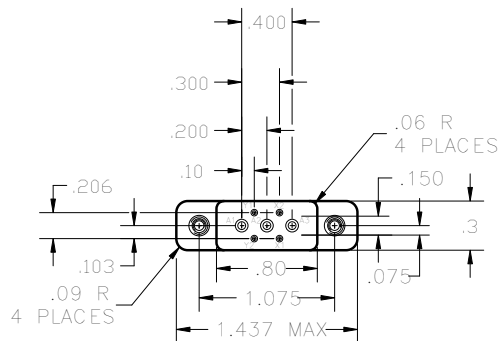

### HARDWARE MOUNTING

MOUNTING DETAIL 2 PLACES

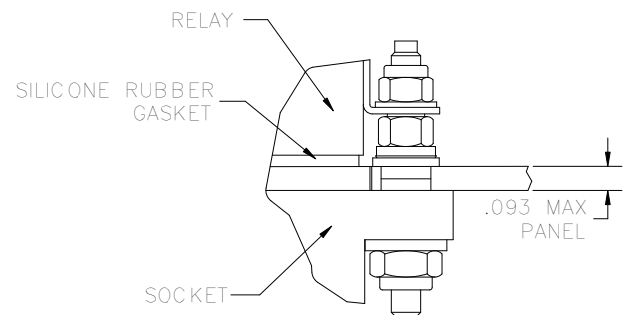

BOTTOM MOUNT-CLEARANCE  
HOLE FOR .164 SCREW  
TOP MOUNT-CLEARANCE  
HOLE FOR .112 SCREW

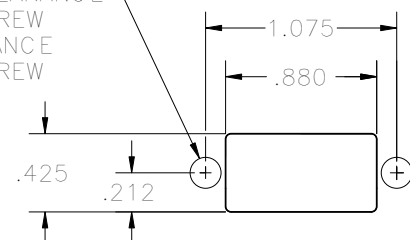

MOUNTING DIMENSIONS

### GENERAL CHARACTERISTICS

1. Supplied with mounting hardware No. 16 contacts, No. 16 crimp for power terminals; No. 20 contacts, No. 20 crimp for coil terminals.

2. Standard tolerances

.xx ±.01; xxx ±.005.

3. Weight

.036 lb. max

4. Temperature range

-70° C to +125° C



Leach International  
www.leachintl.com

**North America**  
6900 Orangethorpe Ave.  
P.O. Box 5032  
Buena Park, CA 90622 USA

Tel: (01) 714-736-7599  
Fax: (01) 714-670-1145

**Europe, SA**  
2 Rue Goethe  
57430 Sarralbe  
France

Tel: (33) 3 87 97 98 97  
Fax: (33) 3 87 97 84 04

**Asia-Pacific Ltd.**  
20/F Shing Hing Commercial Bldg.  
21-27 Wing Kut Street  
Central, Hong Kong

Tel: (852) 2 191 2886  
Fax: (852) 2 389 5803

Data sheets are for initial product selection and comparison. Contact Leach International prior to choosing a component.