



APPLICABLE TRACK:
[MT-3000-003](#)

BASIC SOCKET SERIES DESIGNATION FOR:

Series Y (Track Mount)

QUALIFIED TO:

MIL-DTL-12883/52-002

SOCKET TRACK DRAWING

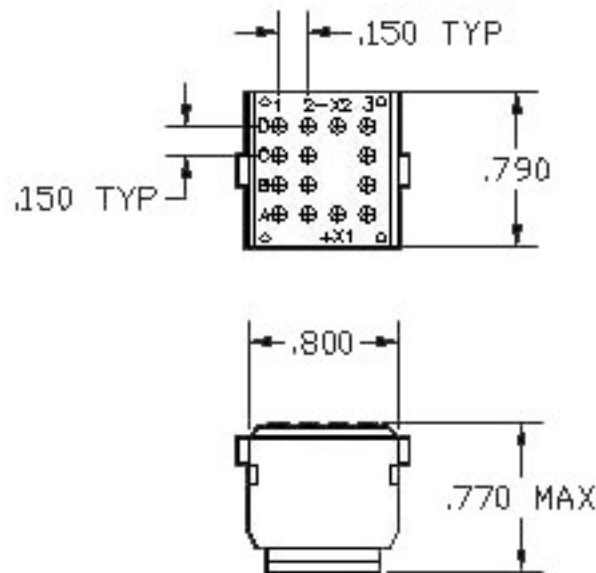

GENERAL CHARACTERISTICS

1. Supplied with No. 20 contacts and No. 20 crimp.

2. Standard tolerances

.xx ±.01; xxx ±.005.

3. Weight

.031 lb. max.

4. Used in conjunction with MT-3000-003



Featuring **LEACH**® power and control solutions
www.esterline.com

AMERICAS
6900 Orangethorpe Ave.
P.O. Box 5032
Buena Park, CA 90622

EUROPE
2 Rue Goethe
57430 Sarralbe
France

ASIA
Units 602-603 6/F Lakeside 1
No.8 Science Park West Avenue
Phase Two, Hong Kong Science Park
Pak Shek Kok, Tai Po, N.T.
Hong Kong

Tel: (01) 714-736-7599
Fax: (01) 714-670-1145

Tel: (33) 3 87 97 31 01
Fax: (33) 3 87 97 96 86

Tel: (852) 2 191 3830
Fax: (852) 2 389 5803

Data sheets are for initial product selection and comparison. Contact Esterline Power Systems prior to choosing a component.

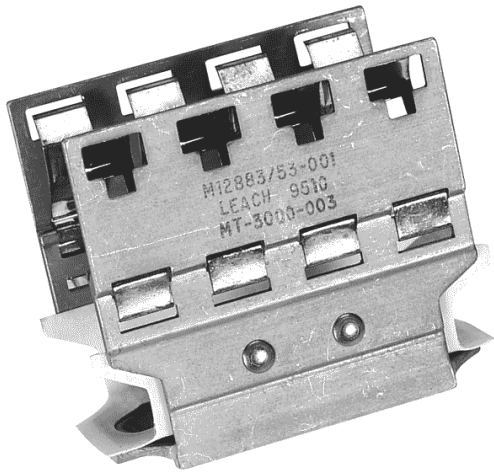

BASIC SOCKET SERIES DESIGNATION FOR:

Series SM Sockets (Track Mount)

MEETS THE REQUIREMENTS OF:

MIL-DTL-12883

SOCKET TRACK DRAWING

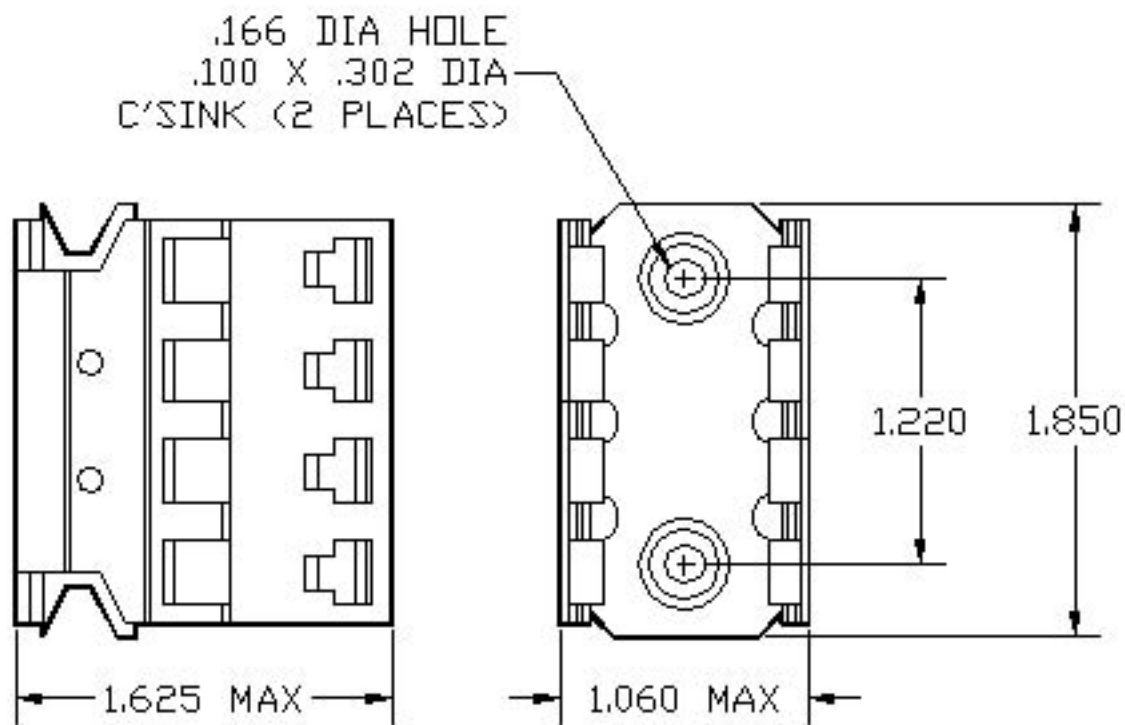

GENERAL CHARACTERISTICS

Used in conjunction with SM-1000-003, SM-1001-003 and SM-1002-003 track mount relay sockets.

Standard tolerances	.xx ±.01; xxx ±.005.
Weight	.056 lb. max.

Esterline Power Systems
Featuring **LEACH**® power and control solutions
www.esterline.com

AMERICAS
6900 Orangethorpe Ave.
P.O. Box 5032
Buena Park, CA 90622

EUROPE
2 Rue Goethe
57430 Sarralbe
France

ASIA
Units 602-603 6/F Lakeside 1
No.8 Science Park West Avenue
Phase Two, Hong Kong Science Park
Pak Shek Kok, Tai Po, N.T.
Hong Kong

Tel: (01) 714-736-7599
Fax: (01) 714-670-1145

Tel: (33) 3 87 97 31 01
Fax: (33) 3 87 97 96 86

Tel: (852) 2 191 3830
Fax: (852) 2 389 5803

Data sheets are for initial product selection and comparison. Contact Esterline Power Systems prior to choosing a component.