

# ENGINEERING DATA SHEET

# SERIES KDA

RELAY - NONLATCH  
3 PST/NO +AUX, 25 AMP

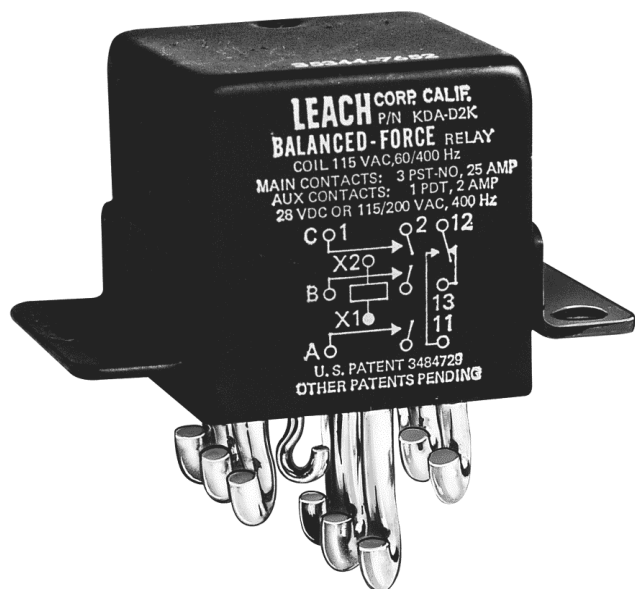

**APPLICATION NOTES:**

[102](#)  
[007](#)

**APPLICABLE SOCKET:**

[SO-1061-8916](#)

All welded construction

Contact arrangement **3 PST configuration with 1 PDT, 2 AMP auxiliary contacts in one inch cube**

Designed to the performance standards of **MIL-PRF-6106**

**PRINCIPLE TECHNICAL CHARACTERISTICS**

Contacts rated at **28 Vdc and 115/200 Vac, 400 Hz, 3Ø**

Weight **0.188lb max**

Dimensions **1.01in x 1.01in x 1.00in**

Hermetically sealed, corrosion resistant metal can.  
Detail specifications and ordering data appear on the following pages.

Contact factory for information on MIL-qualified part numbers.

**CONTACT ELECTRICAL CHARACTERISTICS**

Contact rating per pole and load type [1]	Load current in Amp				
	@28 Vdc	@115 Vac 400 Hz	@115/200 Vac 400 Hz, 3Ø	@115/200 Vac 60 Hz, 3Ø [9]	@230/400 Vac 400 Hz [11]
Resistive [2]	25	25	25	2.5	5
Inductive [3]	12	15	15	2.5	5
Motor	10	10	10	2	2
Lamp	5	5	5	1	2
Overload	50	80	80	N/A	N/A
Rupture	60	100	100	N/A	N/A
<b>Contact rating of auxiliary contacts at 28 Vdc or 115 Vac 400 Hz</b>			<b>Resistive 2 Amp</b>	<b>Inductive 1 Amp</b>	<b>Lamp 0.5 Amp</b>



Featuring **LEACH**® power and control solutions  
[www.esterline.com](http://www.esterline.com)

**AMERICAS**  
6900 Orangethorpe Ave.  
P.O. Box 5032  
Buena Park, CA 90622

Tel: (01) 714-736-7599  
Fax: (01) 714-670-1145

**EUROPE**  
2 Rue Goethe  
57430 Sarralbe  
France

Tel: (33) 3 87 97 31 01  
Fax: (33) 3 87 97 96 86

**ASIA**  
Units 602-603 6/F Lakeside 1  
No.8 Science Park West Avenue  
Phase Two, Hong Kong Science Park  
Pak Shek Kok, Tai Po, N.T.  
Hong Kong  
Tel: (852) 2 191 3830  
Fax: (852) 2 389 5803

Data sheets are for initial product selection and comparison. Contact Esterline Power Systems prior to choosing a component.

**COIL CHARACTERISTICS (Vac)****SERIES KDA**

CODE	Vac 400 Hz		Vac 50-400 Hz		Vac 400 Hz
	E	F	J	K	T [11]
Nominal operating voltage	28	115	28	115	230
Maximum operating voltage	30	122	30	122	248
Maximum pickup voltage					
- Cold coil at +125° C	22	90	23	95	180
- During high temp test at +125° C	24.4	95.4	24.6	100	185
- During continuous current test at +125° C	25.6	103.5	25.9	105	195
Maximum drop-out voltage	10	30	10	30	60
Coil current maximum milliAmperes at +25° C	225	40	120	28	22

**GENERAL CHARACTERISTICS**

Temperature range	-70°C to +125°C
Minimum operating cycles (life) at rated load	50,000 [3]
Minimum operating cycles (life) at 25% rated load	200,000
Dielectric strength at sea level	
- All circuits to ground and circuit to circuit	1250 Vrms
- Coil to ground and coil auxiliary contact gap	1000 Vrms [4]
Dielectric strength at altitude 80,000 ft	500 Vrms [5]
Insulation resistance	
- Initial (500 Vdc)	100 M Ω min
- After environmental tests (500 Vdc)	50 M Ω min
Sinusoidal vibration (A, D and E mounting)	0.12DA / 10 to 70 Hz 30G / 70 to 3000 Hz
Sinusoidal vibration (J mounting)	0.12DA / 10 to 57 Hz 20G / 57 to 3000 Hz
Random vibration	
- Applicable specification	MIL-STD-202
- Method	214
- Test condition - A, D and E mounting	1G (0.4G <sup>2</sup> /Hz, 50 to 2000 Hz)
- Test condition - J mounting	1E (0.2G <sup>2</sup> /Hz, 50 to 2000 Hz)
- Duration	15 minutes each plane
Shock (A, D, E and W mounting)	200G / 6 ms
Shock (J mounting)	100G / 6 ms
Maximum contact opening time under vibration and shock	10 μs
Operate time at nominal voltage@25°C	20 ms max
Release time at nominal voltage@25°C	50 ms max
Contact make bounce at nominal voltage	
- power contacts@25°C	1 ms max
- auxiliary contacts@25°C	4 ms max
Contact release break bounce at nominal voltage	0.1 ms max [8]
Weight maximum	0.188lb

- [1] Standard Intermediate current test applicable.
- [2] For full rated load, max. temp. and altitude use no. 12 wire or larger.  
Relays to be mounted to limit mounting bracket temp. to 135° C.
- [3] DC inductive load 10,000 cycles. AC inductive load 20,000 cycles.
- [4] Dielectric of auxiliary contact gap after life tests: 750 Vrms.
- [5] 500 Vrms with silicone gasket compressed, 350 Vrms all other conditions.
- 6. Reference military specification: MIL-PRF-6106, and MIL-PRF-6106/13.
- 7. Special models available: dry circuit, established reliability testing, etc.
- [8] Applicable to power contacts only.
- [9] 60 Hz load life, 10,000 cycles.
- [10] Time current relay characteristics per MIL-PRF-6106.
- [11] Temperature range:  
Non-operating -62°C to +95°C  
Operating -54°C to +71°C

**NUMBERING SYSTEM**

	KDA-	A	4	F
Basic series designation _____				
1-Mounting Style (A,D,E,J) _____				
2-Terminal Types (1,2,4) [1] _____				
3-Coil Voltage see coil characteristics (E,F,J,K or T) _____				

**MOUNTING STYLES**

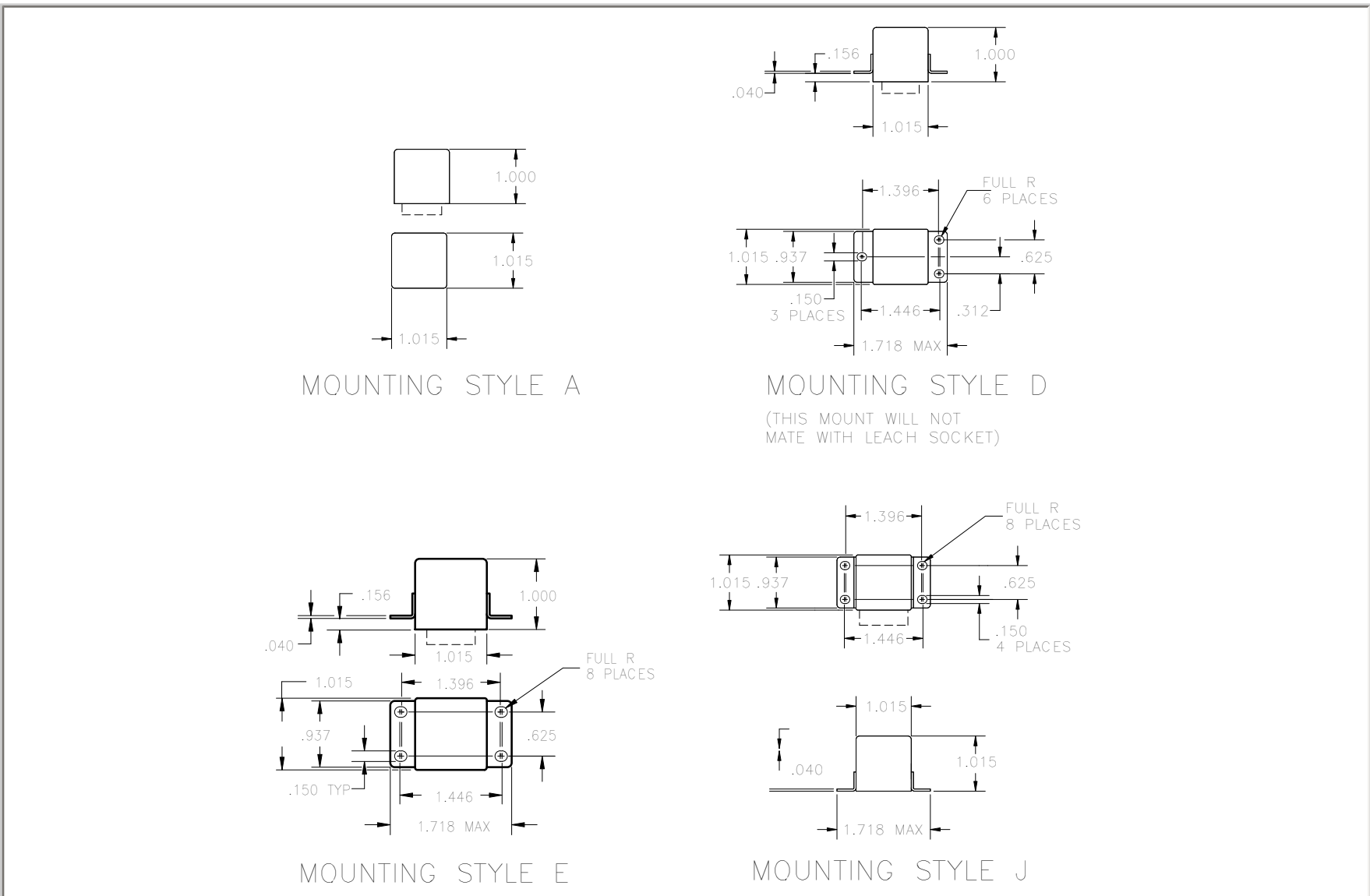

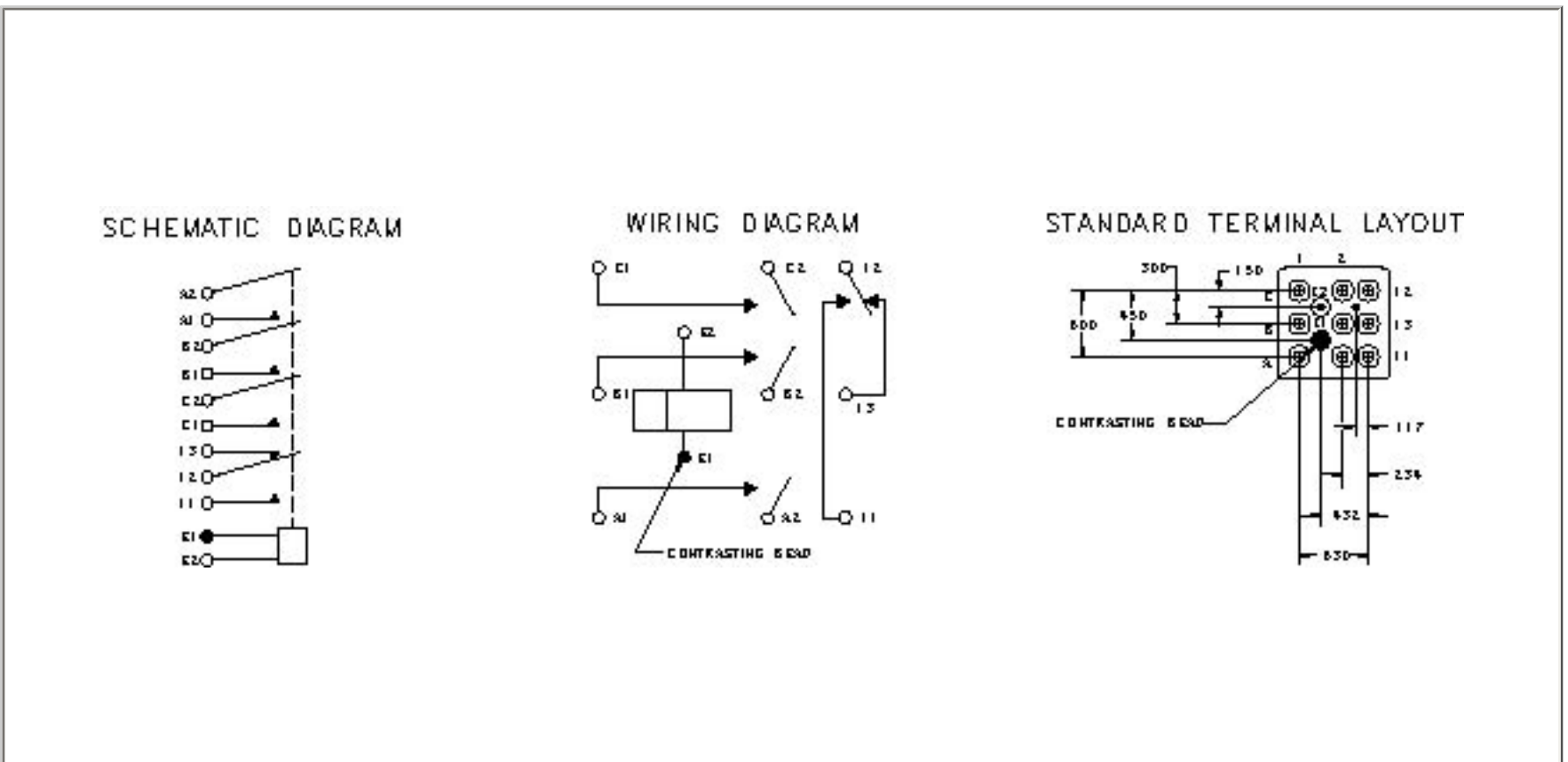
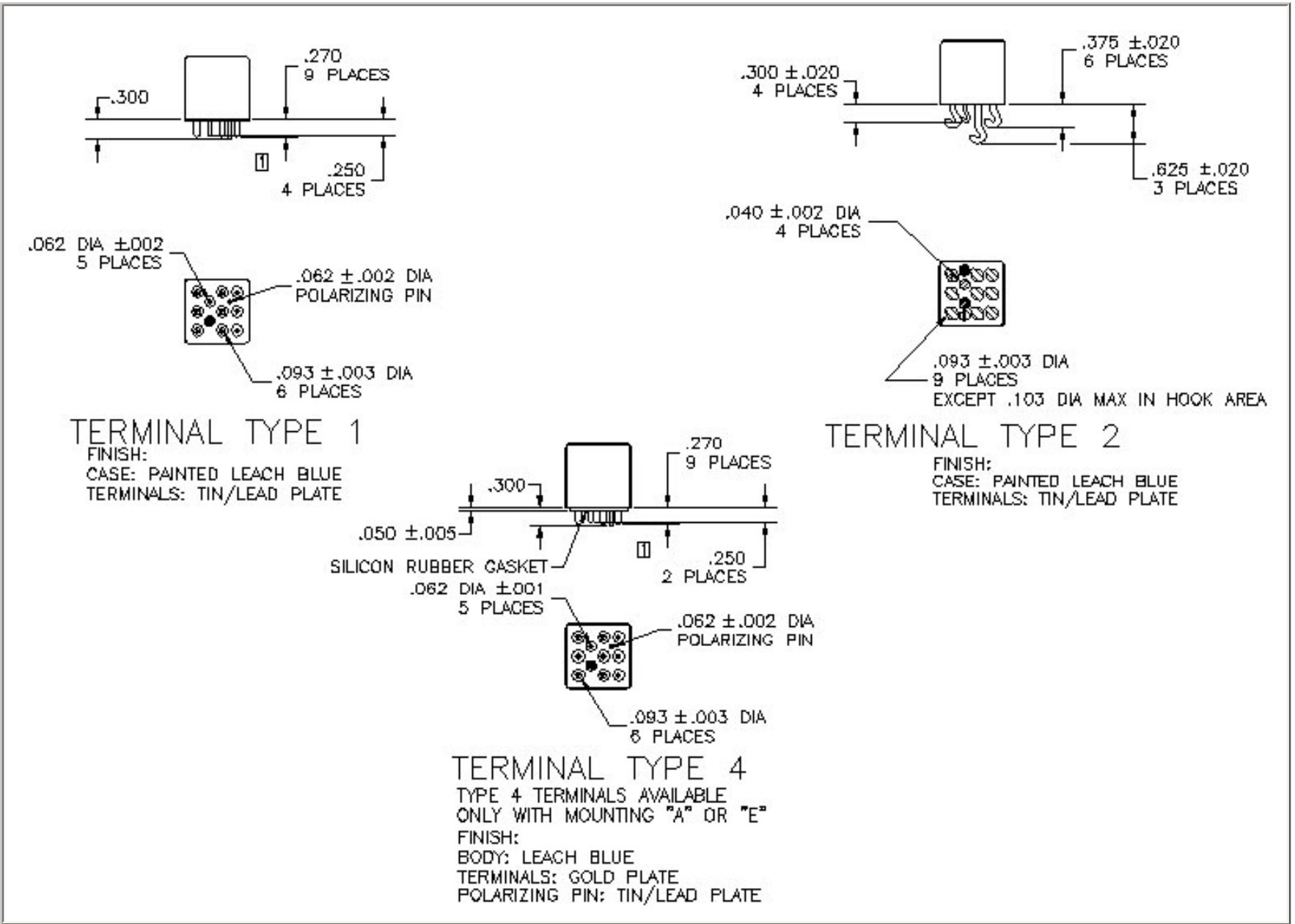

STANDARD TOLERANCE: .XX ±.03; .XXX ±.010

**RELAYS AND TEMPERATURE VARIATIONS**

Most relay parameters are specified as maximum values over the rated temperature range of the specific relay. Users often find that key parameters differ significantly at ambient temperature (20-25°C) and sometimes fall into the trap of specifying their system around these ambient parameters. Additionally the actual temperature experienced by the relay can be far in excess of existing ambient temperatures due to the heat generated by the coil current and the contact load. Figure 1 is the summary of temperature effects on relay electrical characteristics.

Temperature	Resistance	Current	Operating Voltage	Release Voltage	Operate Time	Release Time
Increase	UP	DOWN	UP	UP	UP	UP
Decrease	DOWN	UP	DOWN	DOWN	DOWN	DOWN

**Fig. 1**

The following formulas are sometimes useful in calculating the effects shown above.

1. Change in coil resistance due to change of ambient temperature can be calculated by the following formula.

$$R = R_{20} [1 + .0039 (T-20)]$$

Where: R = Coil resistance at given temperature  
 R<sub>20</sub> = Coil resistance at 20°C  
 T = °C Ambient temperature

"Rule of Thumb" : For each 10°C change of temperature, coil resistance will change approximately 4%.

2. High and low temperature pick up voltage:

$$E_2 = E_1 K_2,$$

Where: E<sub>2</sub> = Pick Up Voltage at T<sub>2</sub> temperature  
 E<sub>1</sub> = Pick Up Voltage at 20°C  
 K<sub>2</sub> = Coefficient of correction found on the graph in Fig. 2 at T<sub>2</sub>

3. Calculation of coil temperature rise when R initial and R final are known:

$$\Delta T = (234.5 + T_1) (R_2/R_1 - 1)$$

$\Delta T$  = Temperature rise ( $^{\circ}\text{C}$ )

$T_1$  = Initial temperature ( $^{\circ}\text{C}$ )

$R_1$  = Initial resistance (Ohms)

$R_2$  = Final resistance (Ohms)

$$R_2 = K_2 R_1$$

Temperature can also be found by making the  $R_2/R_1$  ratio = the coefficient of correction graph in Fig. 2, and then finding the corresponding temperature.

### TEMPERATURE CORRECTION CHART FOR RESISTANCE

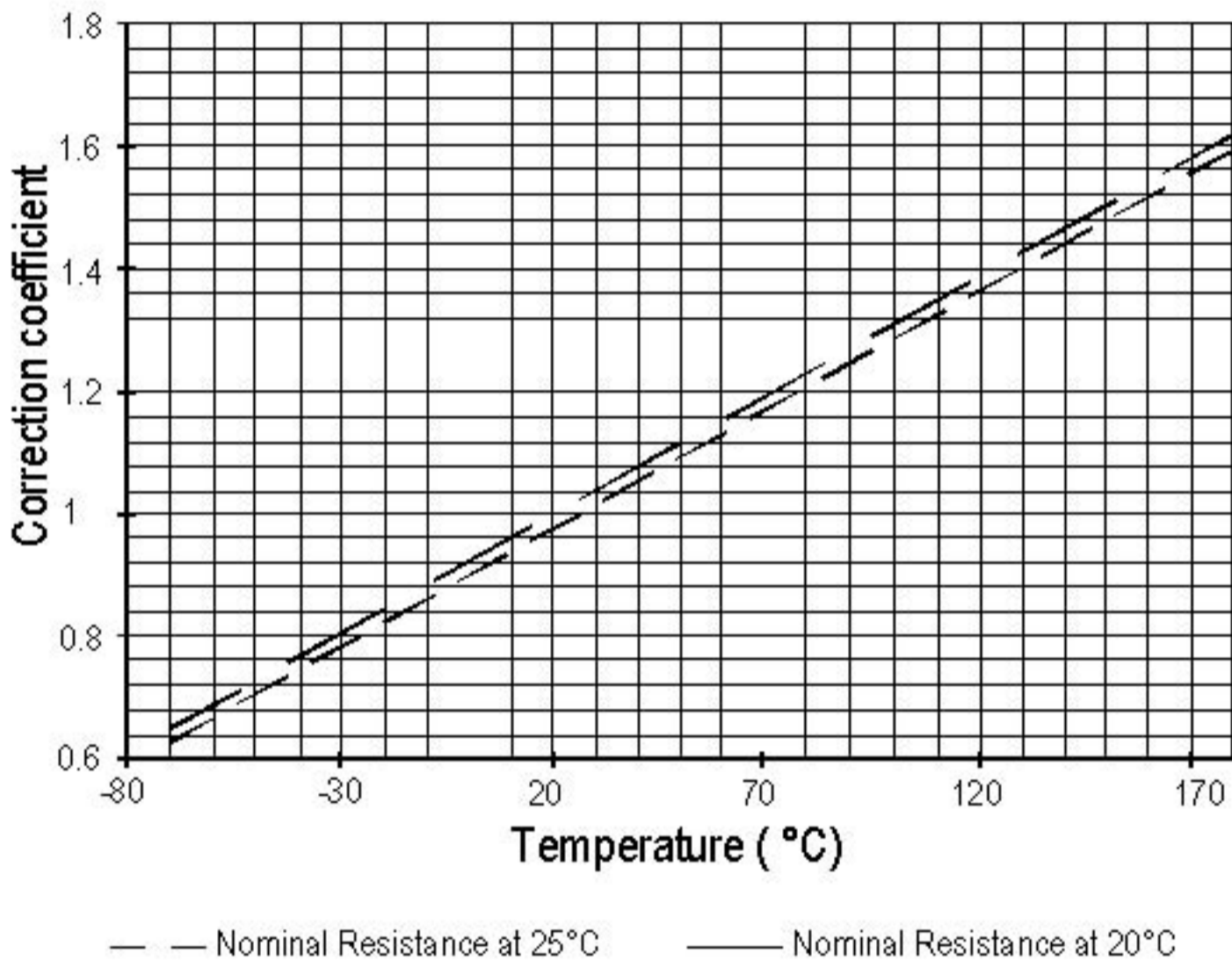

Fig. 2

EXAMPLE:

Catalog indicates coil resistance of 290 ohm at 25 $^{\circ}\text{C}$ . What is the value at 125 $^{\circ}\text{C}$ ?

From the chart: 290 x 1.39 = 403.31 Ohms.

## SUPPRESSOR DEVICES FOR RELAY COILS

The inductive nature of relay coils allows them to create magnetic forces which are converted to mechanical movements to operate contact systems. When voltage is applied to a coil, the resulting current generates a magnetic flux, creating mechanical work. Upon deenergizing the coil, the collapsing magnetic field induces a reverse voltage (also known as back EMF) which tends to maintain current flow in the coil. The induced voltage level mainly depends on the duration of the deenergization. The faster the switch-off, the higher the induced voltage.

All coil suppression networks are based on a reduction of speed of current decay. This reduction may also slow down the opening of contacts, adversely effecting contact life and reliability. Therefore, it is very important to have a clear understanding of these phenomena when designing a coil suppression circuitry.

### Typical coil characteristics

On the graph below, the upper record shows the contacts state. (High level NO contacts closed, low level NC contacts closed, intermediate state contact transfer). The lower record shows the voltage across the coil when the current is switched off by another relay contact.

The surge voltage is limited to -300V by the arc generated across contact poles. Discharge duration is about 200 microseconds after which the current change does not generate sufficient voltage. The voltage decreases to the point where the contacts start to move, at this time, the voltage increases due to the energy contained in the NO contact springs. The voltage decreases again during transfer, and increases once more when the magnetic circuit is closed on permanent magnet.

Operating times are as follows:

Time to start the movement 1.5ms

Total motion time 2.3ms

Transfer time 1.4ms

Contact State

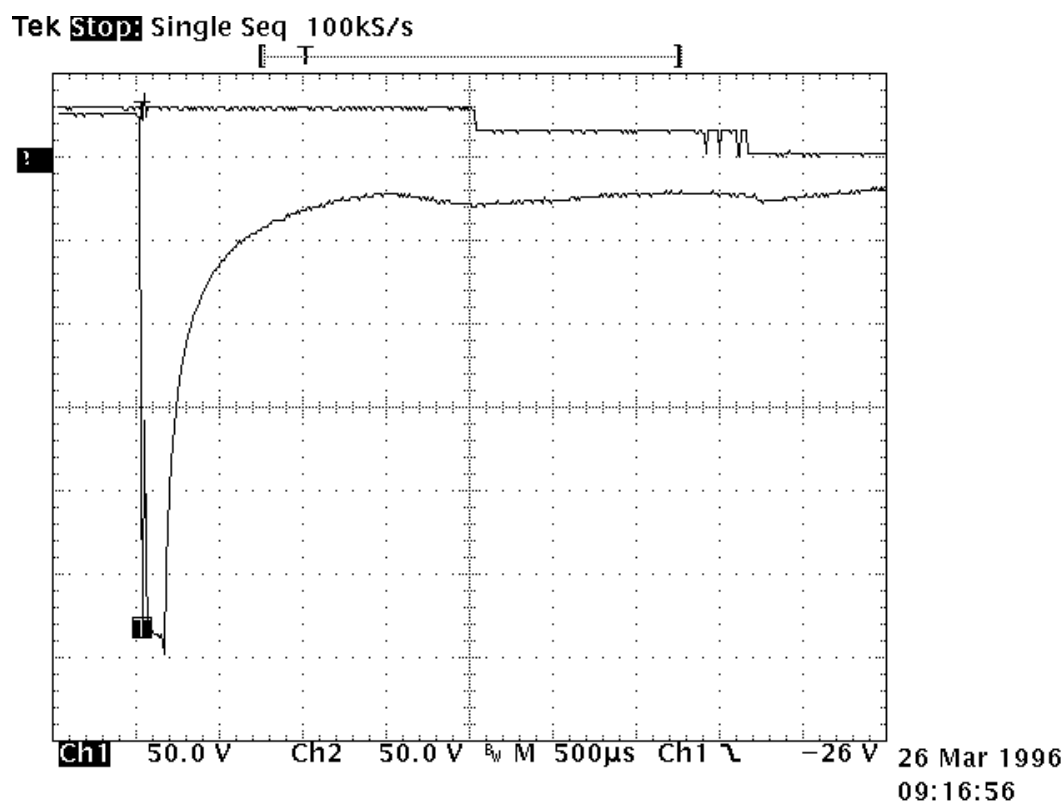

## Types of suppressors:

### Passive devices.

#### The resistor capacitor circuit

It eliminates the power dissipation problem, as well as fast voltage rises. With a proper match between coil and resistor, approximate capacitance value can be calculated from:

$$C = 0.02 \times T/R, \text{ where}$$

T = operating time in milliseconds

R = coil resistance in kiloOhms

C = capacitance in microFarads

The series resistor must be between 0.5 and 1 times the coil resistance. Special consideration must be taken for the capacitor inrush current in the case of a low resistance coil.

The record shown opposite is performed on the same relay as above. The operation time becomes:

- time to start the movement 2.3ms

- transfer time 1.2ms

The major difficulty comes from the capacitor volume. In our example of a relay with a  $290 \Omega$  coil and time delay of 8 ms, a capacitance value of  $C=0.5 \mu\text{F}$  is found. This non polarized capacitor, with a voltage of 63V minimum, has a volume of about  $1\text{cm}^3$ . For 150V, this volume becomes  $1.5 \text{cm}^3$ .

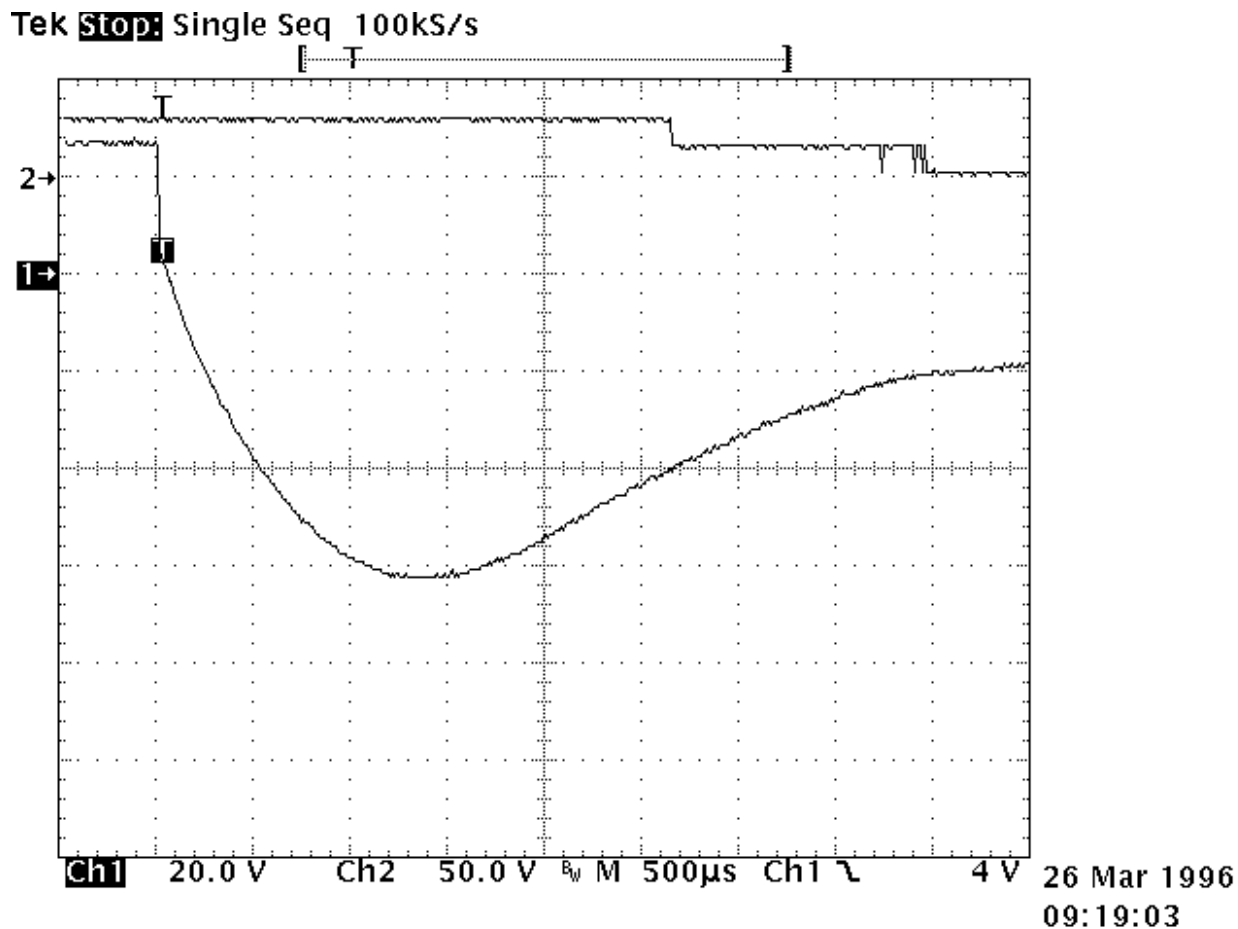

### The bifilar coil

The principle is to wind on the magnetic circuit of the main coil a second coil shorted on itself. By a proper adaptation of the internal resistance of this second coil it is possible to find an acceptable equilibrium between surge voltage and reduction of the opening speed. To be efficient at fast voltage changes, the coupling of two coils must be perfect. This implies embedded windings. The volume occupied by the second coil reduces the efficiency of the main coil and results in higher coil power consumption. This method cannot be applied efficiently to products not specifically designed for this purpose.

### The resistor (parallel with the coil)

For efficient action, the resistor must be of the same order of magnitude as the coil resistance. A resistor 1.5 times the coil resistance will limit the surge to 1.5 times the supply voltage. Release time and opening speed are moderately affected. The major problem is the extra power dissipated.

### **Semi-conductor devices**

#### The diode

It is the most simple method to totally suppress the surge voltage. It has the major disadvantage of the higher reduction of contact opening speed. This is due to the total recycling, through the diode, of the energy contained in the coil itself. The following measurement is performed once again on the same relay. Operation times are given by the upper curve:

- time to start the movement 14ms
- transfer time 5ms

These times are multiplied by a coefficient from 4 to 8.

The lower curve shows the coil current. The increase prior to NO contact opening indicates that the contact spring dissipates its energy. At the opening time the current becomes constant as a result of practically zero opening speed.

Due to this kind of behavior, this type of suppression must be avoided for power relays. For small relays which have to switch low currents of less than 0.2 A, degradation of life is not that significant and the method may be acceptable.

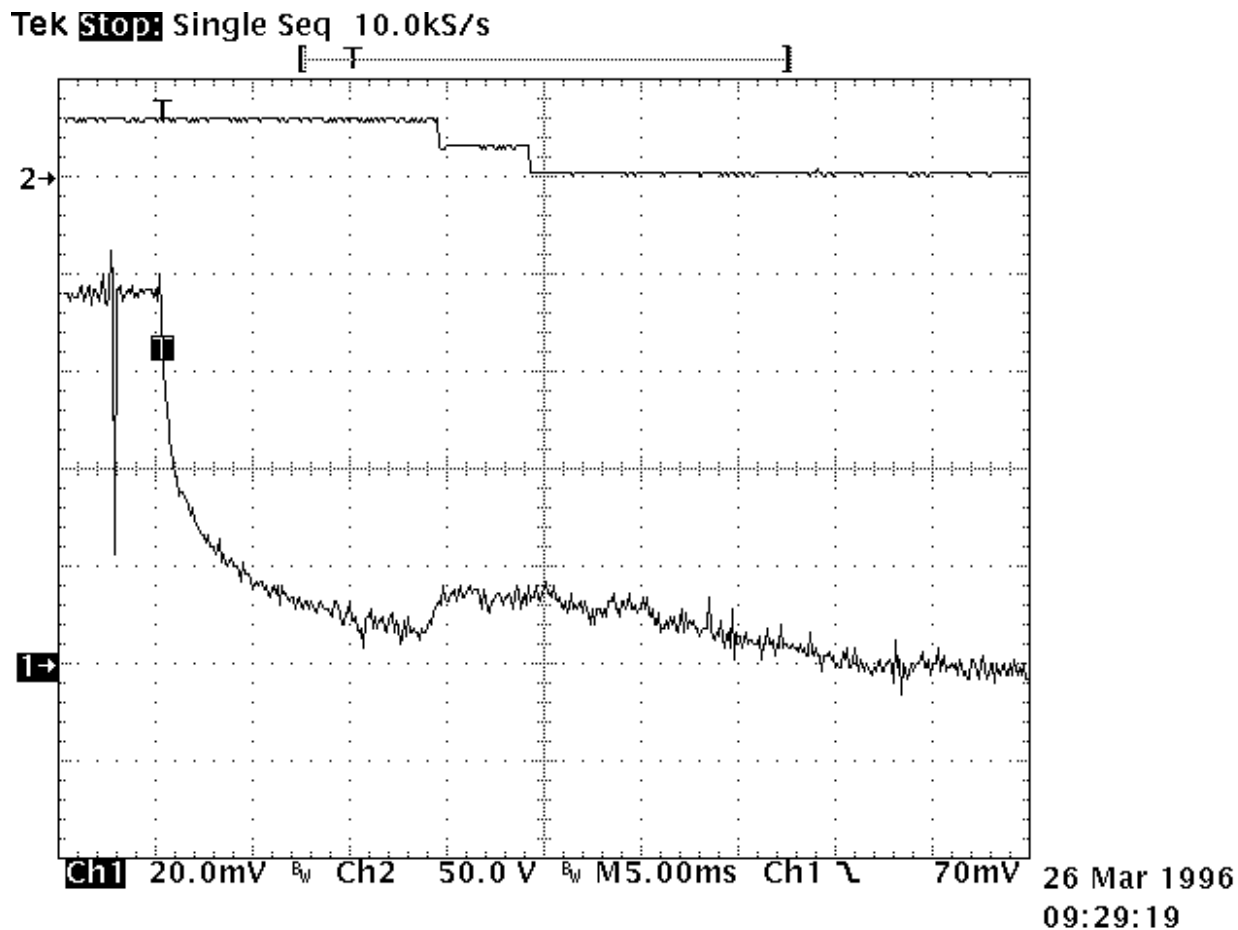

### The diode + resistor network

It eliminates the inconvenience of the resistor alone, explained above, and it limits the action of a single diode. It is now preferred to use the diode + zener network.

### The diode + zener network

Like the resistor, the zener allows a faster decurrent decay. In addition it introduces a threshold level for current conduction which avoids the recycling of energy released during contact movement.

The lower curve on the opposite record demonstrates those characteristics. Voltage limitation occurs at 42V. The two voltage spikes generated by internal movement are at lower levels than zener conduction. As a result, no current is recycled in the coil.

The opening time phases are as follows:

- time to start the movement 2.6ms
- total motion time 2.4ms
- transfer time 1.4ms

The release time is slightly increased. The contacts' opening speed remains unchanged.

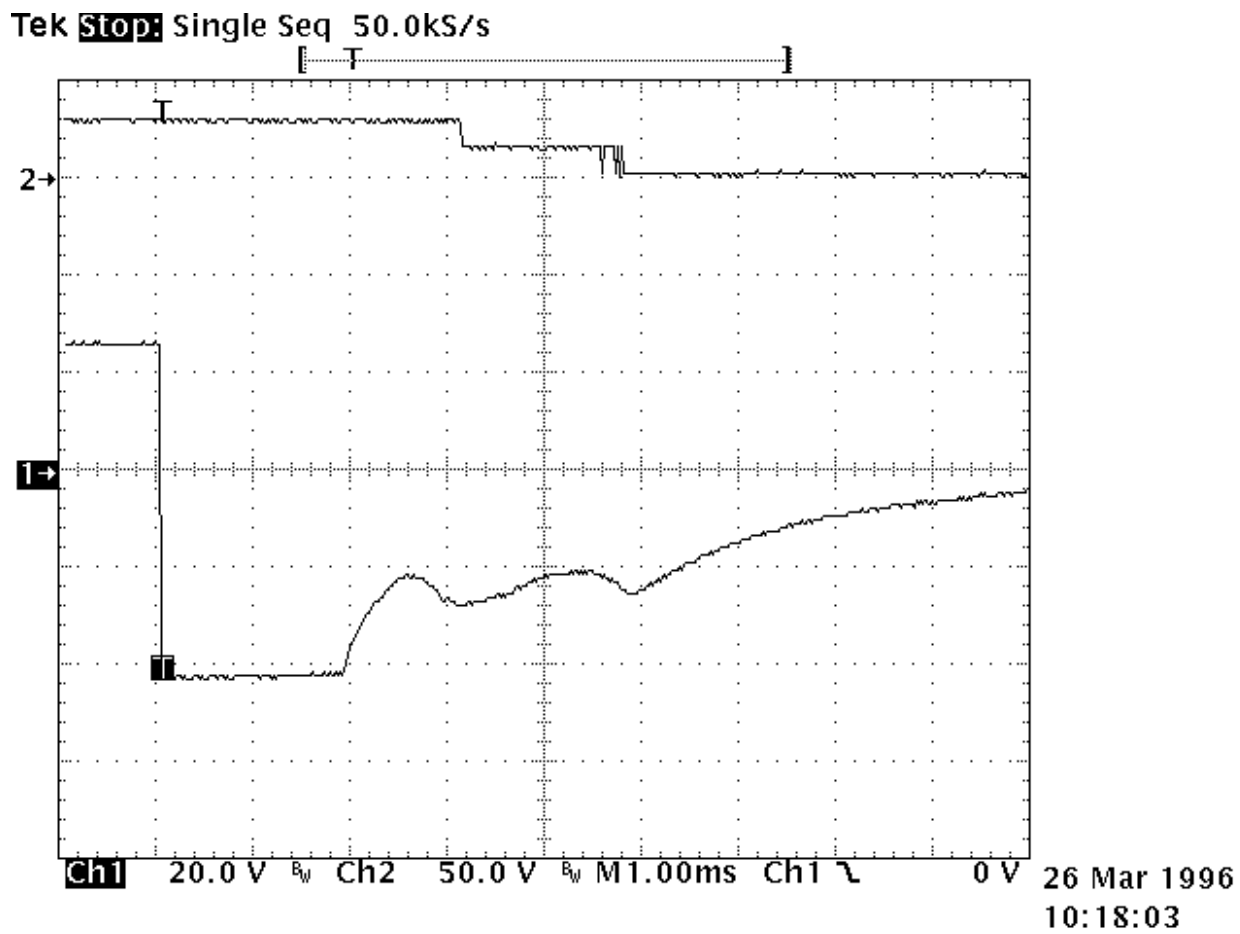

# ENGINEERING DATA SHEET

# SO-1061-8916

RELAY SOCKET  
25 AMP



BASIC SOCKET SERIES DESIGNATION FOR:

**Series KDA**

MEETS THE REQUIREMENTS OF:

**MIL-DTL-12883**

## SOCKET DRAWING

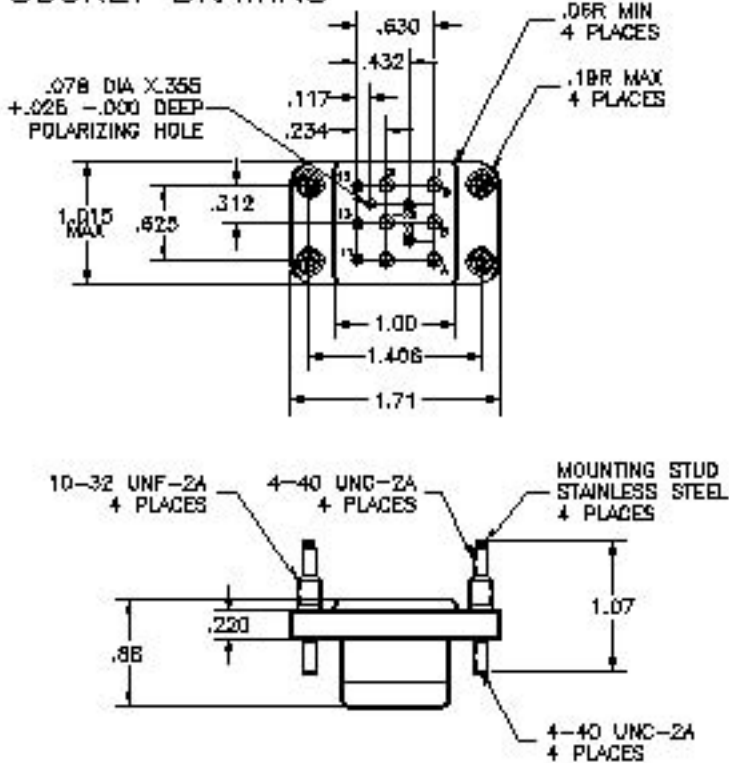

## HARDWARE MOUNTING

MOUNTING DETAIL 4 PLACES

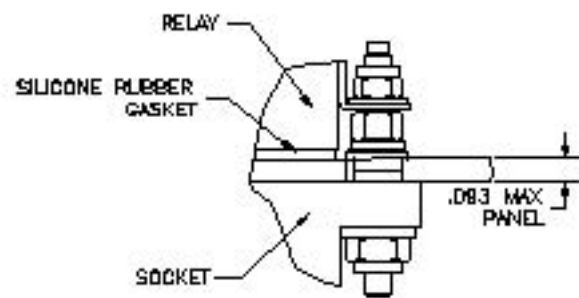

BOTTOM MOUNT-CLEARANCE HOLE FOR .192 SCREW  
TOP MOUNT-CLEARANCE HOLE FOR .112 SCREW

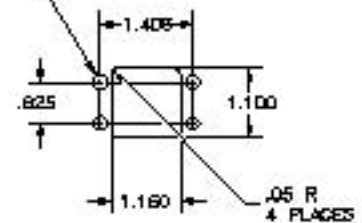

MOUNTING DIMENSIONS  
FOR TYPE "E" MOUNT  
SUGGESTED MOUNTING  
HOLE LAYOUT

## GENERAL CHARACTERISTICS

1. Supplied with mounting hardware and No. 12 contacts, No. 12 crimp for power terminals; No. 16 contacts, No. 16 crimp for coil and auxiliary terminals.

2. Standard tolerances

.xx ±.01; xxx ±.005

3. Weight

.122 lb. max

4. Temperature range

-70° C to +125° C



Featuring **LEACH**® power and control solutions  
www.esterline.com

**AMERICAS**  
6900 Orangethorpe Ave.  
P.O. Box 5032  
Buena Park, CA 90622

**EUROPE**  
2 Rue Goethe  
57430 Sarralbe  
France

**ASIA**  
Units 602-603 6/F Lakeside 1  
No.8 Science Park West Avenue  
Phase Two, Hong Kong Science Park  
Pak Shek Kok, Tai Po, N.T.  
Hong Kong

Tel: (01) 714-736-7599  
Fax: (01) 714-670-1145

Tel: (33) 3 87 97 31 01  
Fax: (33) 3 87 97 96 86

Tel: (852) 2 191 3830  
Fax: (852) 2 389 5803

Data sheets are for initial product selection and comparison. Contact Esterline Power Systems prior to choosing a component.